

EDON fiberglass

<http://www.edon.com>

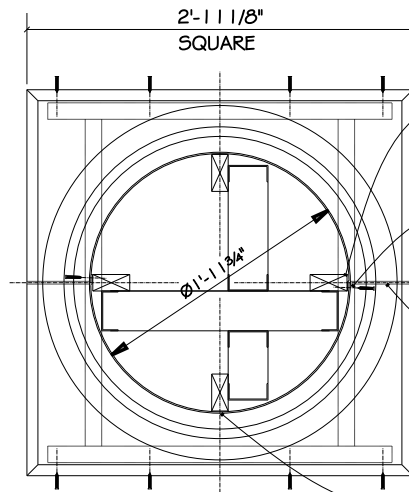
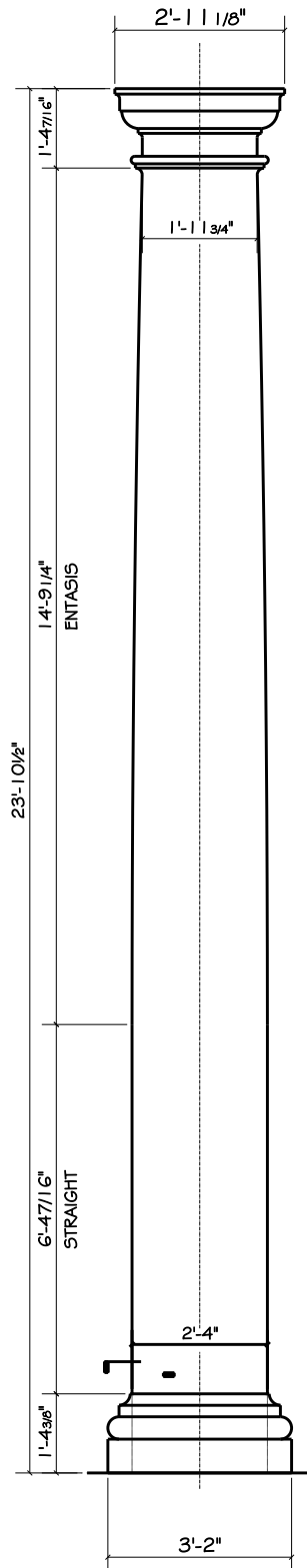

CAPITAL FROM BELOW

RIP PRESSURE TREATED 2x6 TO CONFORM TO INSIDE PROFILE OF LAP JOINT

STAINLESS STEEL FLATHEAD SCREWS COUNTERSUNK AND PATCHED

BUTT FLANGE ASSEMBLY JOINT @ CAPITAL (APPLY ADHESIVE / SEALANT TO FLANGES PRIOR TO ASSEMBLY)

USE CONSTRUCTION ADHESIVE TO FASTEN COLUMN TO BLOCKING AT THIS LOCATION

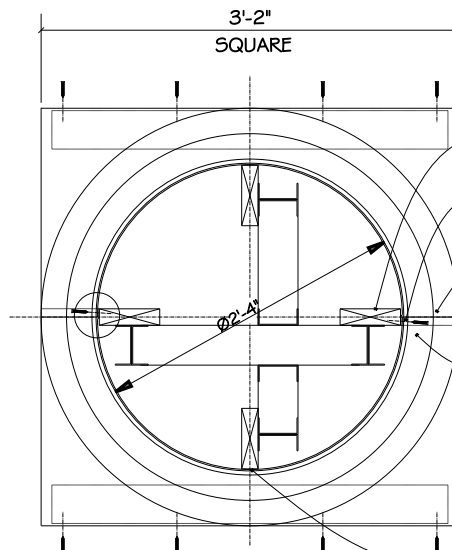

PLAN OF BASE

RIP PRESSURE TREATED 2x6 TO CONFORM TO INSIDE PROFILE OF LAP JOINT

STAINLESS STEEL FLATHEAD SCREWS COUNTERSUNK AND PATCHED

COLUMN AND BASE SEAMS TO BE FINISHED IN FIELD BY INSTALLER

COLUMNS AND BASES TO BE ASSEMBLED AND PAINTED IN THE FIELD

USE CONSTRUCTION ADHESIVE TO FASTEN COLUMN TO BLOCKING AT THIS LOCATION

EC-120Y 28" DIA. TUSCAN COLUMN COVER W/ENTASIS