



HADDONSTONE

Fine garden ornaments
and architectural stonework



INTRODUCTION

Welcome to the Haddonstone catalogue, containing the world's most comprehensive collection of fine ornamental and architectural cast stone.

Established in 1971, Haddonstone has expanded to become an international group with offices and manufacturing facilities in both the United Kingdom and the United States of America. Today, we continue to manufacture all UK orders in England, whilst 95% of all American orders are made by the company in the US.

If you are an existing client, Haddonstone trusts that you will find this catalogue continues to inspire. If this is your first introduction to the company, we hope that you will shortly be joining the many leading architects, landscape designers, contractors, specifiers, interior designers and private clients that we already serve.

This catalogue has been divided into colour-coded sections for ease of use. The Specialist Services section highlights products and services outside the scope of the main catalogue, whilst the Latest Designs section includes all our recent introductions.

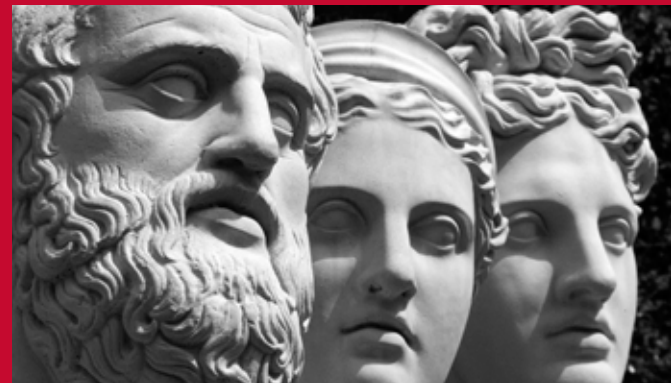

CONTENTS

INTRODUCTION	PAGE 3
LATEST DESIGNS	PAGE 7
GARDEN & LANDSCAPE	PAGE 19
ARCHITECTURAL CAST STONE	PAGE 111
SPECIALIST SERVICES	PAGE 175
USEFUL INFORMATION	PAGE 193
INDEX	PAGE 202



WHY HADDONSTONE?

Haddonstone is a unique form of cast limestone with a surface texture similar to Portland stone. The material matures and weathers like natural stone yet, piece for piece, normally costs significantly less than quarried stone.

The ability to mould the Haddonstone material into almost any shape ~ faithfully reproducing new designs or producing replicas that are virtually indistinguishable from an antique original ~ has won the company numerous contracts ranging from leading international hotels and retail developments to listed National Trust properties and prestige residential projects.

The material used in every design, from the smallest planter to the largest Corinthian column, exceeds the compressive cube strength requirements of the United Kingdom Cast Stone Association and complies with all relevant UK and European standards, whilst TecStone also meets the requirements of all US standards.

Each design is hand made by Haddonstone in the UK or USA using moulds created within the company's extensive mould shops and studios. Using these same facilities Haddonstone can even manufacture non-standard architectural stone pieces to practically any shape, size or colour.

As Haddonstone maintains original models and/or moulds for every single design in the standard collection, and utilises the very latest vapour curing technology, customers can be reassured that the high quality of each stone produced is incredibly consistent whilst retaining the individuality of a hand-made product. The company even offers a five year warranty on cast stone garden ornaments.

Haddonstone can also be an enjoyable investment. At a Sotheby's auction, four Haddonstone Plaited Baskets sold for more than twenty times their current retail value.

Haddonstone ~ one of the few things in life that can grow more beautiful and valuable with the passing of the years.

VISIT US

At East Haddon, in the rolling countryside of Northamptonshire in England, Haddonstone has beautiful show gardens and an interior showroom where visitors can see many of the designs illustrated in this catalogue in their proper settings, see opposite. The garden and showroom are open every week from Monday to Friday - public holidays and Christmas period excepted - between the hours of 9.00 am and 5.00 pm. The gardens are also open on occasional weekends as part of the National Garden Scheme (Yellow Book) to raise money for charity as well as some Saturdays during the Summer months. Brown tourism signs guide visitors to the gardens from the A428.

Haddonstone pieces may also be viewed at stockists across the UK as well as the RHS gardens at Wisley and Harlow Carr. Haddonstone's catalogue can be obtained from the Building Centre, Store Street, London WC1 or viewed online at: www.haddonstone.com/view-catalogue

In the USA, Haddonstone offices have a permanent showroom display, whilst Haddonstone designs may also be viewed at stores and distributors across North America.





LATEST DESIGNS



Haddonstone continues to work with leading architects, designers and museums around the world. The result of our most recent collaborations with the Sir John Soane's Museum, Adam Architecture and Robert A.M. Stern are included in this section.

Attention to detail and a commitment to design quality have resulted in the creation of these new designs, comprising a wide range of interior and exterior products. Having been identified as a market leader with a reputation for outstanding replication and design, superb performance and unparalleled customer service, Haddonstone is proud to have been chosen to create new designs in partnership with these illustrious organisations.

General Note: It is essential that garden ornaments are sited on a firm and level area. An 8 to 1 sand/cement bedding mortar should be used to ensure that the weight of the garden ornaments are spread evenly, avoiding any pivoting or twisting strain. Haddonstone cannot accept responsibility for cracking or breakage if this instruction is ignored.

Soane Caryatid	8
Soane Mouth of Truth Mask	8
Soane Corybantes Plaque	9
Soane River God Mask	9
Soane Dancing Girl & Faun Plaque	9
Soane Hercules	10
Soane Term	10
Orleans Bowl	11
Large Orleans Bowl	11
Large Fontainebleau Urn	11
Large Georgian Pedestal	11
Rhubarb Forcer	12
Gothic Fountain	
with Lion Centrepiece	12
Athenian Wall Fountain	13
Promenade Box	13
Classic Fireplace	13
Gibbs Collection of Porches	14
Inspirations	16

LATEST DESIGNS SIR JOHN SOANE'S MUSEUM COLLECTION

At the 2014 Chelsea Flower Show, Haddonstone launched a fabulous collection of designs, replicated from historic works of art on display at the renowned Sir John Soane's Museum in London. Sir John Soane (1753-1837) was one of the most inventive and celebrated architects of his time. His surviving works include Pitzhanger Manor, Ealing, and his house in Lincoln's Inn Fields, London (now the Soane Museum) which is probably his greatest legacy. The Museum contains his astonishing collection of artefacts. Under the licencing agreement between Haddonstone and the Museum, the Museum will benefit financially from every sale made from the exquisite Soane Museum Collection. This is a rare opportunity to acquire a design from the Museum's historic collection for your own home, garden or landscape. All these designs are made by Haddonstone under licence from the Sir John Soane's Museum.



Soane Mouth of Truth Fountain **TLC972** Soane Mouth of Truth Mask **TLQ972** (not illustrated)

This large mask is similar to the Bocca della Verità in Rome that famously features in Audrey Hepburn's 1953 film "Roman Holiday". Dating from the Roman Hadrianic period or later, with its theatrical appearance, the Soane Mouth of Truth Mask features an open mouth with flowing hair and can be used as a wall plaque or can be adapted for use as a built-in wall fountain. An intriguing design that would be equally at home in a contemporary or classical setting.

Height: 640mm (25¼")
Width: 647mm (25½")

Depth: 85mm (3⅜")
Weight: 42kg (93 lb)



Soane Caryatid **HE675**

The most notable design being replicated by Haddonstone is the wonderful Soane Caryatid, originally created by the famous Coade & Sealy company in 1812. This would have been one of the last designs created during John Sealy's lifetime as he died in 1813. A pair of these female figures stand on top of the projecting stone façade of Soane's house in Lincoln's Inn Fields. Soane used these caryatids in a number of projects, notably at his Bank of England and at Pitzhanger Manor, his country house in Ealing. The original Coade caryatid design was based on ancient Greek sculptures at the Erechtheion temple on the Acropolis in Athens, where the caryatids support an entablature. Coade modified the design to create a magnificent free-standing figure.

Height: 1806mm (71⅝")
Maximum base width: 460mm (18⅛")
Weight: 446kg (982 lb)

Soane Corybantes Plaque TLQ975

Corybantes were armed dancers who worshipped the Phrygian goddess Cybele with drumming and music. Soane owned two casts taken from a celebrated original Roman relief at the Vatican Museum. Found at Palestrina, the panel is taken from a first century copy of an original dating from the fourth century BC.

Height: 710mm (28") Max depth: 63mm (2½")
Width: 725mm (28½") Weight: 31kg (68 lb)



Soane River God Mask TLQ970

The Soane Museum original is a design created by the famous Coade manufactory and dates from c1775. Attributed to the English sculptor John Bacon (1740-1799) and probably inspired by the seventeenth century garden sculptures at Versailles, the mask is in the form of a keystone and can be used as an architectural feature or simply as an intriguing interior decoration or in a landscape.

Height: 585mm (23") Width at base: 295mm (11⅝")
Width at top: 435mm (17⅛") Max depth of base block: 55mm (2⅛")
Weight: 30kg (66 lb)



Soane Dancing Girl & Faun Plaque TLQ977

A charming plaque with a relief depicting a dancing girl and faun. A faun was believed by the ancients to be half man, half goat who lived in the forests, a manifestation of forest and animal spirits that would help or hinder humans at whim.

Height: 712mm (28") Base depth: 37mm (1½")
Base width: 725mm (28½") Weight: 38k (84 lb)



Soane Term E679

Terms are classical architectural features, the name deriving from Terminus, the Roman god of boundaries and boundary markers. The Soane Term incorporates a human head with a sunflower motif and a sculptured drop of flowers and fruit reminiscent of the style of Grinling Gibbons. The original can be seen in the Monument Court at the Soane Museum. Ideal for use inside or out, positioning either side of an entrance or against a wall at the end of a path or corridor.

Height: 1905mm (75") Base width: 255mm (10")
 Base depth: 100mm (4") Weight: 76kg (167 lb)



Soane Hercules E677

A colossal bust based on the full length figure of the famous Farnese Hercules in the Museo Archeologico Nazionale in Naples. Previously displayed at the Palazzo Farnese in Rome, the design is believed to be a copy made in the early third century AD from a fourth century BC original by Lysippos. It was discovered in the Baths of Caracalla in 1546. At the Soane Museum the bust is displayed on a parapet overlooking the Monument Court. Recommended pedestal: B265

Height: 1170mm (46") Width at base: 380mm (15")
 Max width: 812mm (32") Weight: 231kg (509 lb)



Orleans Bowl A485

A large, stylish planter adapted from the Fontainebleau Urn A300 (see page 33) Shown on B120 Georgian Pedestal (see page 60).

Width at top: 915mm (36")

Height: 425mm (16³/₄")

Width at base: 470mm (18¹/₂")

Weight: 161kg (354 lbs)



Large Fontainebleau Urn A302

A large, elegant urn based to the existing Fontainebleau Urn A300 (see page 33) which was replicated from an XVIII century marble original. Will require mechanical lifting on site in all instances.

Width at top: 1200mm (47¹/₄")

Height: 832mm (32³/₄")

Width at base: 616mm (24¹/₄")

Weight: 225kg (496 lbs)

Large Georgian Pedestal B122

Large and imposing pedestal with deep recessed mouldings based on the existing Georgian Pedestal (see page 60). Will require mechanical lifting on site in all instances.

Width at base: 918mm (36¹/₈")

Width at cap: 964mm (38")

Height: 1123mm (44¹/₄")

Weight: 950kg (2093 lbs)



Large Orleans Bowl A487

A larger version of the Orleans Bowl. Will require mechanical lifting on site in all instances. Shown on B122 Large Georgian Pedestal

Width at top: 1200mm (47¹/₄")

Height: 600mm (23⁵/₈")

Width at base: 616mm (24¹/₄")

Weight: 258kg (568 lbs)



LATEST DESIGNS

Rhubarb Forcer TLA532

This new Rhubarb Forcer is based on a traditional design yet made from the company's unique TecLite material, meaning it is of a thin-wall construction - making it easier to move whilst being frost resistant, unlike most terracottas.

The use of rhubarb forcers has been well established in England since the early nineteenth century. Rhubarb forcers encourage the plant to grow and, once the lid is removed, encourages the shoots to grow towards the light. The perfect addition to a kitchen garden or cottage garden, whether used purely as an ornament or for improving rhubarb cultivation.

Height excluding lid: 450mm (17³/₄"

Diameter: 350mm (13³/₄"

Weight: 20kg (44 lbs)

Gothic Fountain with Lion Centrepiece

C253

Gothic Upper Base

A350 (optional)

The design comprises a self-circulating Gothic octagonal fountain containing a unique lion head centrepiece. Supplied with offset cable hole unless specified. Includes pump and plumbing. Shown here on an optional Gothic Upper Base, supplied in four sections. A complementary design to the Gothic Fountain (see page 106) and Gothic Jardiniere (see page 45), the Gothic Fountain with Lion Centrepiece was launched at the 2013 Chelsea Flower Show.

Fountain width: 800mm (31¹/₂"

Fountain with Lion Centrepiece overall height: 1030mm (40¹/₂"

Fountain with Lion Centrepiece weight: 271kg (597 lbs)

Upper Base width: 1092mm (43"

Upper Base height: 89mm (3¹/₂"

Upper Base weight: 128kg (282 lbs)



Athenian Wall Fountain TLC928

This elegant, self-circulating wall fountain is a new design to complement the Athenian Collection of planters and pedestals created by Haddonstone in partnership with Robert A.M.Stern (see pages 57-59). Supplied with pump and pump cover.

Width of bowl: 740mm (29 $\frac{1}{8}$ "")
 Projection from wall:
 405mm (16 $\frac{1}{4}$ "")
 Overall height: 1234mm (48 $\frac{1}{2}$ "")
 Weight: 72kg (159 lb)
 Heaviest Component:
 47kg (104 lb)



Promenade Box HA528

Featuring a generous square planting area, the Promenade Box is ideal for any landscape scheme. It is possible to cast lettering or dates into this box during production. For Promenade Trough see page 50.

Height: 597mm (23 $\frac{1}{2}$ "")
 Length 717mm (28 $\frac{1}{4}$ "")
 Width: 717mm (28 $\frac{1}{4}$ "")
 Weight: 287kg (633 lbs)



Classic Fireplace HF640

The Classic Fireplace is the latest design to be launched by Haddonstone as part of the Robert A.M. Stern Collection. Manufactured in Haddonstone's TecLite material to ease handling and installation. Includes Hearth. Optional Slips available.

Height: 1305mm (52 $\frac{1}{8}$ "") Width at base: 1727mm (68")
 Height of opening: 1015mm (40") Hearth: 1968 x 518 x 38mm (77 $\frac{1}{2}$ " x 20" x 1 $\frac{1}{2}$ "")
 Width of mantel: 1968mm (77 $\frac{1}{2}$ "") Weight overall: 209kg (460 lb)
 Width of opening: 1219mm (48")

ROBERT A.M. STERN COLLECTION

LATEST DESIGNS

THE GIBBS RANGE OF CLASSICAL PORCHES

The Gibbs Range of classical porches is inspired by the designs of the famous Georgian architect James Gibbs (1682-1754). Gibbs's design handbooks about classical architecture were probably the most widely used in the eighteenth century across the Western world. It is this rich legacy that makes Gibbs's version of the Classical Orders the most appropriate for this new range of porch designs, being equally suitable for both new and historic buildings across Great Britain, The United States of America, and around the world.

The Gibbs range of porches is designed to offer flexibility to architects, builders, and home owners for any situation. A simple matrix shows how the components may be combined to create a wide variety of designs, using the rules, geometry and proportions of classical architecture, to produce beautiful and original compositions. The Gibbs Range include both elaborate and more restrained details so that the character of the porch can be finely tuned to each site.



The Gibbs range is conceived around the two oldest and most widely used Orders — the Doric and Ionic. Over the centuries, generations of Classical architects have adapted the proportions of these two Orders to suit a variety of situations. The Gibbs range is rooted in this fertile tradition, and offers correctly proportioned designs at an affordable price.

James Gibbs was one of the first British architects to go to Italy. Whilst studying for the priesthood in Rome, he turned to architecture in 1704. He became a pupil of Carlo Fontana before returning to London where, with help from Sir Christopher Wren, he became one of the two surveyors to the Commissioners for Building 50 New Churches in London in 1713. His masterly design of St Mary Le Strand in London (1714-24) launched his reputation; St Martins in the Fields in Trafalgar Square (1722-26) became the prototype for urban Anglican churches for the next century across the UK and America.

James Gibbs's prolific portfolio of secular buildings included Sudbrooke House, Petersham (c1717-20), the Senate House, Cambridge (1722-30); the Fellows Building, Kings College Cambridge (1724-49), and the Radcliffe Library, Oxford (1737-8).

ADAM ARCHITECTURE

The Gibbs Range has been designed by Hugh Petter, a leading authority on classical architecture, and a design director of Adam Architecture, one of the largest firms of traditional architects currently practicing in the world.

For further information on the Gibbs Range of classical porches see:

www.haddonstone.com/porch

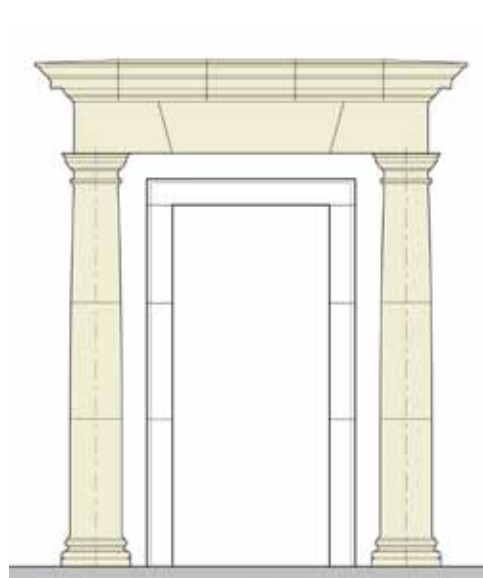

Gibbs I

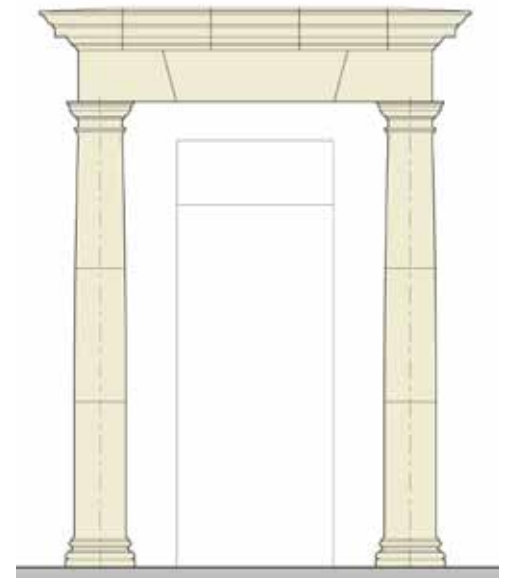

Gibbs I

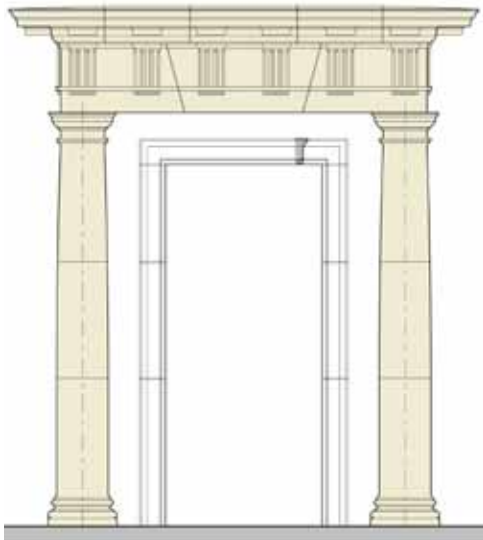

Gibbs II

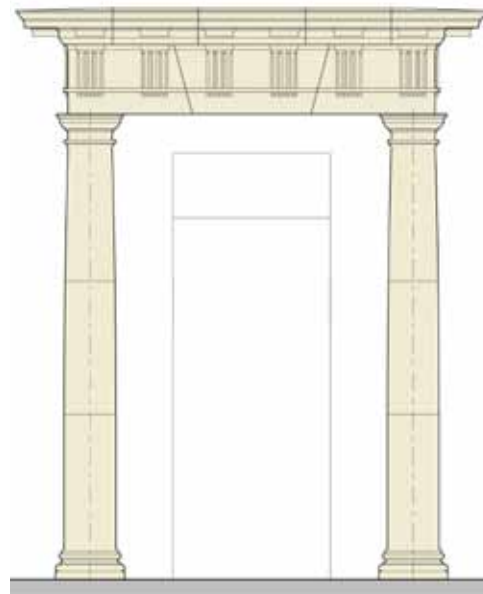

Gibbs II

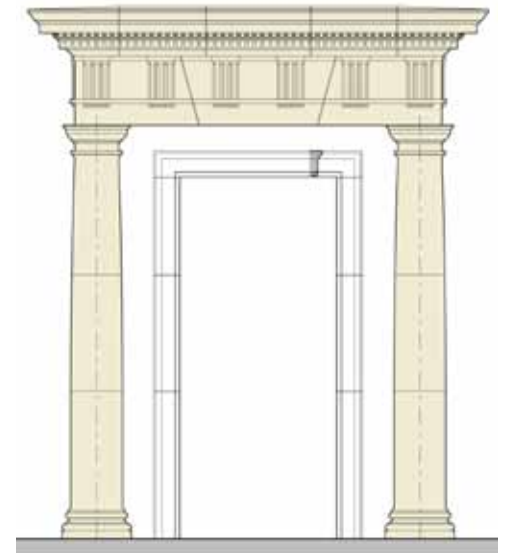

Gibbs IV

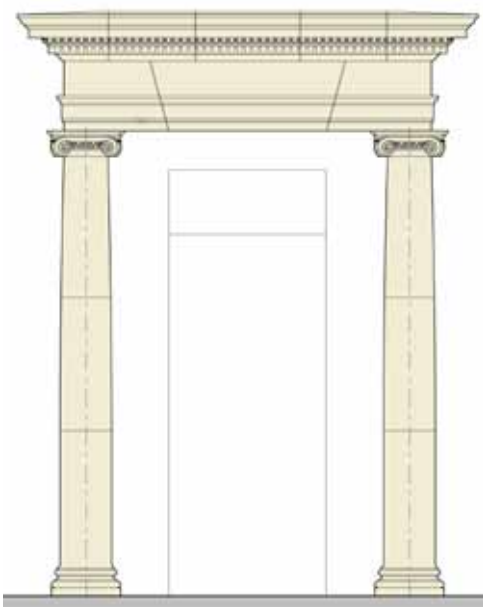

Gibbs III

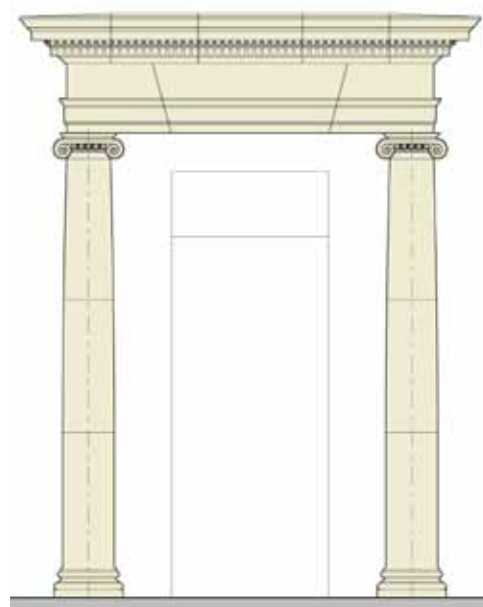

Gibbs III

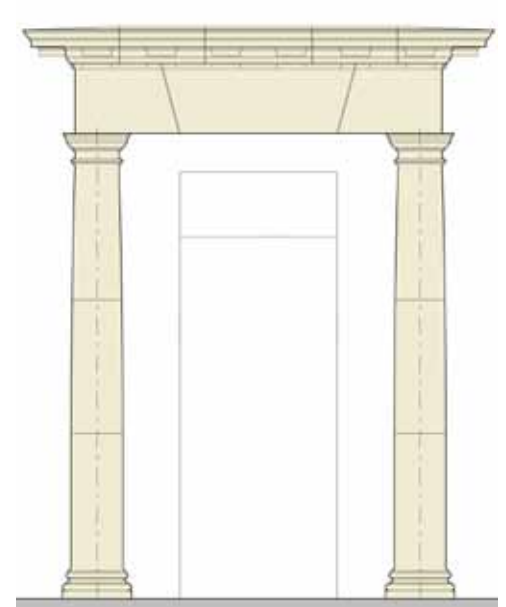

Gibbs V

LATEST INSPIRATIONS

Sir Roy Strong's Laskett Gardens are the largest private formal gardens to be created in England since 1945. Over almost four decades he has transformed a four acre field into a series of stunning garden rooms, vistas, ascents and descents. The gardens and his house feature many Haddonstone designs, from statues and finials to garden structures and house façade embellishments.

Images by Clive Boursnell from *Remaking a Garden: The Laskett Transformed* by Roy Strong.





The prestigious Totteridge Manor project by Domus London.



Impressions by Evalina Steele

Custom façade created for Roberts Stadium Club, Florida.



Haddonstone works closely with major architects and developers to create custom residences. Shown is part of the Wootton Place project by Octagon Developments in Esher. All the stonework is by Haddonstone.



GARDEN & LANDSCAPE



Ever since English gardens began to be influenced by those of Italy, urns, fountains and statues have found an honourable, often the most honourable, place in their scheme. They contribute very much to the embellishment and magnificence of a garden, whether large or small, terraced or open-ground.

“Garden ornaments provide emphasis and accent in a garden, drawing the eye in a particular direction. Most ornaments, because they are solid and static objects such as urns, seats, columns or statues, provide a contrast with the living things around them.”

David Hicks, 1929-1998

Inspirations	20
Planters - Traditional	26
Planters - Contemporary	51
Pedestals and Plinths	58
Sundials	63
Bird Baths & Bird Tables	67
Statues	69
Garden Pet Memorials	82
Finials	83
Balls & Bases	86
Garden Furniture	87
Fountains - Centrepiece	91
Fountains - Pool Surrounds	97
Lighting	103
Fountains - Self-Circulating	104
Fountains - Wall	111
Plaques	115
Garden Decor & Accents	117
Obelisks	118
Lawn Edging	120

GARDEN & LANDSCAPE INSPIRATIONS

By studying the following pages, you will see how, with imagination and inspiration, architects and designers have used Haddonstone designs to great effect in a variety of gardens and landscapes.

Each project has been achieved by using either standard Haddonstone components or custom-made designs created by utilising the company's skilled craftsmen and extensive mould-making facilities.

Whether standard or custom-made, within reason, the only constraint is your imagination...



Colonnade at the Grade I listed Dyffryn Gardens near Cardiff.



Haddonstone has been used extensively at this major South Korean project.



Haddonstone's obelisk is used to great effect at the RHS Gardens, Rosemoor.



Evocative urban garden incorporating Large Versailles Vases and Pedestals.

Design: Anthony Noel. Image: Andrew Lawson



Haddonstone balustrading can be used to enhance both residential and commercial projects.



The unique landscape at this private residence in Dorset incorporates both standard and custom-made designs including a special Triple Lotus Bowl Fountain and two Naiad statues, replicating the work of John Bacon RA by Croggon of Lambeth.



Haddonstone's Pavilion, Pergola and ornaments enhance the historic garden of an important Grade I listed property located in Surrey.



Standard architectural components including steps, risers and finials combine to create a unique garden feature at this magnificent home counties residence.

GARDEN & LANDSCAPE INSPIRATIONS



A Haddonstone pergola provides a focal point at Roosevelt Park, Chicago.



Architects: Scholz Design. Photographer: Beth Singer Photographer Inc.

Roman Pool Surround and ornaments at a splendid residence in Pittsburgh.



Haddonstone landscape ornaments and architectural stonework combine with great effect at this Ohio residence.

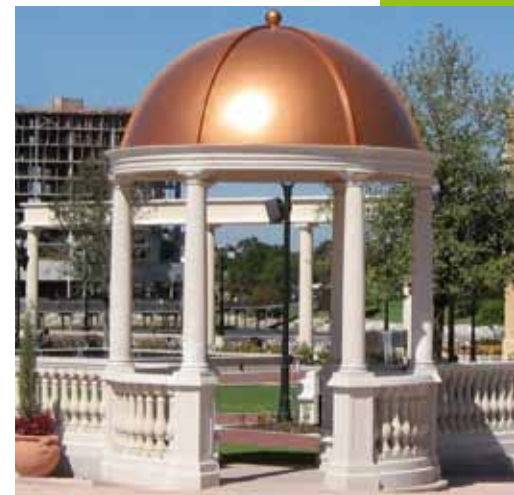

Temple and balustrading enhance Altamonte Springs, Florida.



Client: Kilworth House Hotel

Majestic balustrading at a prestigious Leicestershire hotel.



Intriguing shapes from custom copings at the University of Southampton.



Massive M1 columns create a focal point at an entrance to Manchester's Trafford Centre.



These massive custom spheres were created for Northampton's Racecourse.



Haddonstone landscape ornaments and architectural designs combine to create a magnificent entrance at the West Midlands Golf Club.

GARDEN & LANDSCAPE INSPIRATIONS



Haddonstone Pergola and ornaments at King James Quay, Old Portsmouth.



Special Copings are used to provide seating at the Eden Project in Cornwall.



Haddonstone Pavilion built as a ruin at Tower Hill Botanic Garden, MA, USA.

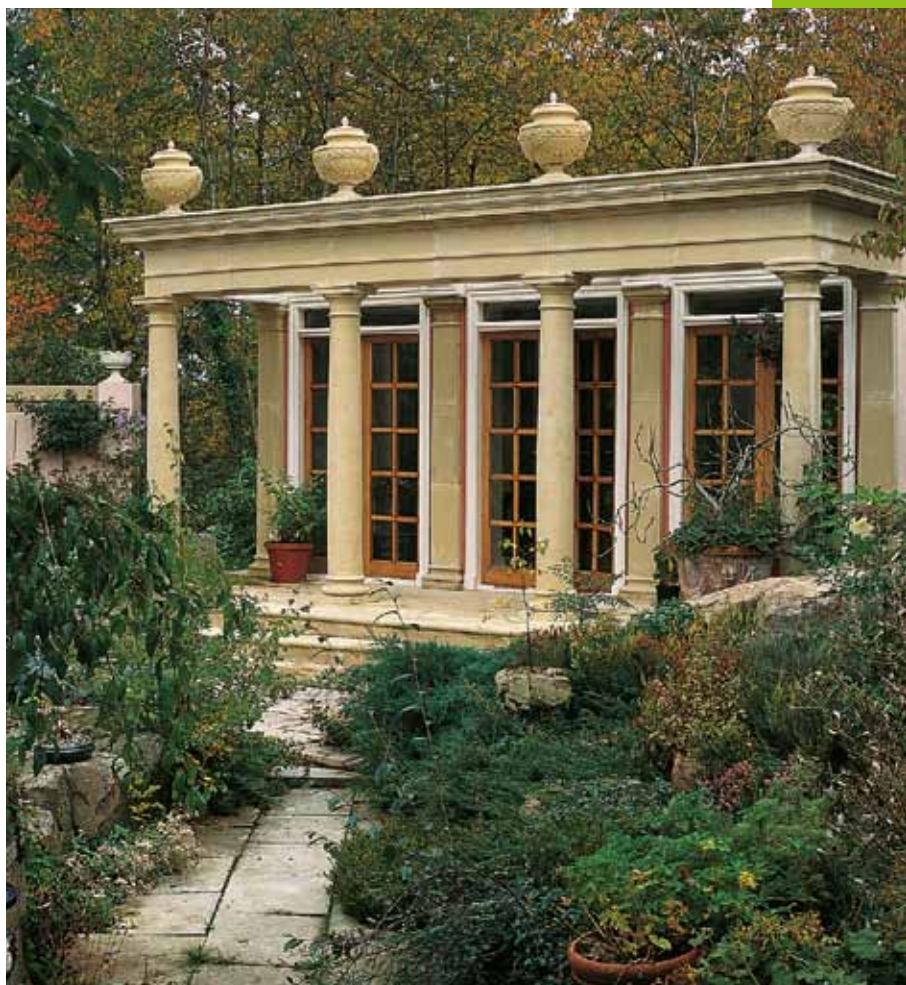

A beautiful Orangery constructed in Northern Scotland solely using Haddonstone standard architectural components and decorated with Margam Swagged Urns.

GARDEN & LANDSCAPE PLANTERS - TRADITIONAL

Clarence Urn A215

This elegant urn, inspired by the designs of the Regency period, has been crafted by Haddonstone as a complementary piece to the Regency and Trafalgar Urns. The simple design has leaf moulding to the rim and gadrooning to the bowl. Identical in proportion to the Large Clarence Urn A214, see page 33.

Width at top: 540mm (21")
Width at base: 242mm (9½")
Height: 430mm (17")
Weight: 40kg (88 lb)

Recommended pedestals: B300, B310, B331, B400, B420, B440.

(Registered Design No. 2045998)



Croyland Vase A245

A small campana-shaped vase featuring a stylised leaf design. This vase was replicated from an original in a private Northamptonshire garden.

Width at top: 470mm (18½")
Width at base: 240mm (9½")
Height: 500mm (19½")
Weight: 32kg (70 lb)

Recommended pedestals: B300, B310, B400, B420, B440.

(Registered Design No. 2082024)

Magnolia Vase A490

A simple campana-shaped vase with a circular base incorporating acanthus-leaf moulding around the bowl. The original dates back to the XVII century in the style of Christopher Wren.

Width at top: 395mm (15½")
Diameter of base: 280mm (11")
Height: 510mm (20")
Weight: 35kg (77 lb)

Recommended pedestals: B300, B310, B400, B420, B440.

Vine Urn A705

This charming small urn features vine decoration and gadrooning to the body and overlapping leaf decoration around the rim. Ideal for use in conjunction with Haddonstone balustrading.

Width at top: 343mm (13½")
Width at base: 197mm (7¾")
Height: 430mm (17")
Weight: 21kg (45 lb)

Recommended pedestals: B130, B300, B310, B330, B400, B420, B440, B480.

(Registered Design No. 2039119)

Lotus Vase A470

An octagonal Regency-style vase with a beautiful lotus-leaf design carved on the vase and base. Replicated from an XIX century Blashfield original.

Width at top: 405mm (16")
Width at base: 320mm (12½")
Height: 495mm (19½")
Weight: 40kg (88 lb)

West Lodge Urn

HA780

Featuring gadrooning to the bowl, this elegant small urn was originally replicated for West Lodge Park Hotel in Hertfordshire. See also, West Lodge Fountain, page 91.

Height: 527mm (20³/₄"

Width overall: 660mm (26")

Width at base: 273mm (10³/₄"

Weight: 74kg (163 lb)

Recommended pedestals: B300, B310, B400, B420, B440.



Regency Urn

A530

Regency Pedestal

B330

This popular urn is shown on a simple pedestal and can also enhance balustrading.

Width at urn top: 485mm (19")

Width at urn base: 220mm (8³/₄"

Pedestal base width: 280mm (11")

Height of urn: 380mm (15")

Height of pedestal: 430mm (17")

Weight of urn: 30kg (66 lb)

Weight of pedestal: 33kg (73 lb)

Alternative pedestals: B130, B300, B310, B400, B420, B440, B480.



Trafalgar Urn

A620

An urn of early XIX century design with egg and dart moulding around the rim and a fluted base. This urn can be used as a decorative ornament on balustrade piers.

Width at top: 585mm (23")

Width at base: 240mm (9¹/₂"

Height: 430mm (17")

Weight: 48kg (106 lb)

Recommended pedestals: B300, B310, B331, B400, B420, B440, B695.



Sheraton Vase

A610

Designed by Haddonstone, this charming vase features gadrooning and fluting to the bowl, enriched around the rim with rods and ribbons in the style of Sheraton. Ideal for interior planting in conservatories and garden rooms.

Height: 355mm (14")

Width overall: 395mm (15¹/₂"

Width at base: 230mm (9")

Weight: 32kg (70 lb)

Recommended pedestals: B300, B310, B331, B400, B420, B440, B480.



House of Dun Urn

A420

Commissioned by the National Trust for Scotland to replace the originals at the House of Dun as part of the major restoration programme. The Trust has since granted permission to include the urn in the Haddonstone Collection.

Width at top: 330mm (13")

Width at base: 195mm (7³/₄"

Height: 425mm (16³/₄"

Weight: 24kg (53 lb)

Recommended pedestals: B130, B300, B310, B330, B400, B420, B440, B480.

GARDEN & LANDSCAPE PLANTERS - TRADITIONAL

Gothic Urn and Base A370

A Regency-period octagonal urn with single quatrefoil panels mounted on a waisted square base. These impressive urns line the Rose Walk at Lambeth Palace. Gothic Vase (see below), Gothic Jardiniere (page 45) and Large Gothic Jardiniere (page 44) also available.

Width at top of urn: 620mm (24½")

Width at base of urn: 355mm (14")

Width of base: 485mm (19")

Height of urn: 585mm (23")

Height overall: 745mm (29¼")

Weight overall: 150kg (330 lb)



Florentine Urn A290

Reproduced from an ornate early XIX century urn acquired from Florence, this design is swathed in a rich vine relief, with gadrooning around the base.

Width at top: 585mm (23")

Width at base: 335mm (13¼")

Height: 890mm (35")

Weight: 115kg (253 lb)

Recommended pedestals:
B255, B265, B350, B370



Etruscan Vase A280

The beautiful Etruscan Vase was commissioned by a private client and features a simple campana shape with gadrooning to the bowl and an egg and dart rim.

Width at top: 420mm (16½")

Width at base: 195mm (7½")

Height: 460mm (18")

Weight: 19kg (42 lb)

Recommended pedestals: B130,
B300, B310, B330, B400, B420,
B440, B480.



Versailles Vase A690

A simple campana-shaped stone vase with restrained gadrooning to the bowl. Identical in proportion to Large Versailles Vase A680, see page 34. This design was replicated from a Blashfield original.

Width at top: 535mm (21")

Width at base: 255mm (10")

Height: 685mm (27")

Weight: 50kg (110 lb)

Recommended pedestals: B255,
B265, B300, B310, B331, B400,
B420, B440, B695.



Gothic Vase A380

Regency-style octagonal vase with single quatrefoil panels. Ideal for decorating a terrace. Gothic Urn and Base (see above), Gothic Jardiniere (page 45) and Large Gothic Jardiniere (page 44) also available.

Width at top: 565mm (22¼")

Width at base: 400mm (15¾")

Height: 590mm (23¼")

Weight: 70kg (154 lb)

Eastwell Urn

A260

A large, elegant tazza with elaborately interlaced ribbonwork decoration around the bowl. It can also be supplied in fountain form as a centrepiece (see C200 on page 96).

Width at top: 785mm (31")

Width at base: 350mm (13¾")

Height: 595mm (23½")

Weight: 89kg (195 lb)

Recommended pedestals: B255, B265, B350, B370



Shugborough Vase

A585

The Shugborough Vase is a replica of an original we were commissioned to replace at Shugborough Hall. The proportions of this vase allow its use as a decorative ornament to enhance Haddonstone balustrading.

Width at top: 320mm (12½")

Width overall: 420mm (16½")

Width at base: 215mm (8½")

Height: 430mm (17")

Weight: 40kg (88 lb)

Recommended pedestals: B300, B310, B330, B400, B420, B440, B480



Cliveden Vase

A220

The National Trust commissioned this replica to replace damaged vases at Cliveden, Buckinghamshire.

Width at top: 415mm (16¼")

Width overall: 520mm (20½")

Width at base: 285mm (11¼")

Height: 560mm (22")

Weight: 82kg (182 lb)

Recommended pedestals: B255, B265, B331



Large Acanthus Urn

Q997

Taken from a Doulton original of c1840, this elegant design features bold gadrooning and acanthus leaf decoration.

Width at top: 360mm (14¼")

Width overall: 595mm (23½")

Width at base: 380mm (15")

Height: 805mm (31¾")

Weight: 144kg (317 lb)

Recommended pedestals: B255, B265, B370



Warwick Castle Urn

A740

Haddonstone was commissioned by Warwick Castle to reproduce this urn as part of the castle's restoration project for the rose garden.

Width at top: 405mm (16")

Width overall: 560mm (22")

Width at base: 355mm (14")

Height: 510mm (20")

Weight: 78kg (173 lb)

Recommended pedestals: B255, B265, B370.

French Urn A320

A facsimile of a Renaissance campana-shaped urn with medallion and intricate relief of vine leaves. The underside of the bowl and the neck are decorated with acanthus leaves.

Width at top: 660mm (26")
Width at base: 330mm (13")
Height: 650mm (25½")
Weight: 96kg (211 lb)

Recommended pedestals: B255, B265, B350, B370



Small Haddo House Urn A395 Large Haddo House Urn A390

Haddonstone was commissioned by the National Trust for Scotland to replicate these urns. Haddo House is a splendid design by William Adam, built between 1732 and 1735 for William, 2nd Earl of Aberdeen. The campana-shaped urns that adorn the grounds are decorated with restrained gadrooning to the bowl incorporating scrolled handles.

Small Haddo House Urn:

Width at top: 570mm (22½") Height: 755mm (29¾")
Width at base: 305mm (12") Weight: 68kg (150 lb)
Recommended pedestals: B255, B265, B350

Large Haddo House Urn:

Width at top: 650mm (25½") Height: 885mm (34¾")
Width at base: 330mm (13") Weight: 95kg (209 lb)
Recommended pedestals: B255, B265, B350, B370

Zahra Vase A790

The abstract pattern of this vase with stylised Ashoka buds, tendrils and leaf nodes results from a cultural blend of Islamic and Indian traditions.

Width at top: 580mm (22¾")
Width at base: 430mm (17")
Height: 660mm (26")
Weight: 120kg (264 lb)

Hadrian Vase A404 (without handles)

The Hadrian Vase combines a half-gadrooned bowl with egg-and-dart rim, a circular socle and square base. The Hadrian Vase is also available with handles, see right.

Width at top: 760mm (30")
Width at base: 350mm (13¾")
Height: 685mm (27")
Weight: 158kg (348 lb)

Recommended pedestals: B255, B265, B350

Turn to Specialist Services - Archives for further ornament options



Hadrian Vase

A405 (with handles)

The Hadrian Vase combines a half-gadrooned bowl with egg-and-dart rim, two scroll and foliate carved handles, a circular socle and square base. The Hadrian Vase is also available without handles, see left.

Maximum width: 970mm (38")

Height: 840mm (33")

Width at base: 350mm (13¾")

Weight: 171kg (377 lb)

Recommended pedestals: B255,
B265, B350

GARDEN & LANDSCAPE PLANTERS - TRADITIONAL

Westonbirt Urn A755

Commissioned as a commemoration by the governors of Westonbirt School, Gloucestershire. The original was manufactured by Pulham from a design attributed to the architect Lewis Vulliamy who was active in the early XIX century. This scaled-down version is typical of his style, featuring spiralled gadrooning and egg-and-dart rim.

Width at top: 700mm (27¾") Height: 650mm (25½")
Width at base: 380mm (15¼") Weight: 129kg (285 lb)

Recommended pedestals: B255, B265, B370



Winslow Vase A770 Winslow Pedestal B350

An unusual design with fluted decoration and leaf mouldings. Its elegant proportions make it ideal for entrances and walkways.

Width at vase top: 620mm (24½")
Width at vase base: 300mm (11¾")
Pedestal top width: 355mm (14")
Pedestal base width: 525mm (20¾")
Height of vase: 865mm (34")
Height of pedestal: 205mm (8")
Weight of vase: 84kg (186 lb)
Weight of pedestal: 57kg (125 lb)

Recommended pedestals: B255, B265, B350, B370



Swagged Adam Vase A605

Adapted from Haddonstone's popular finial, see page 71, the Swagged Adam Vase is a stylish planter featuring drapery swags.

Width overall: 495mm (19½")
Width at base: 229mm (9")
Height: 530mm (20⅞")
Weight: 50kg (110 lb)

Recommended pedestals: B420, B440, B490, B495.



Ionian Vase A425

This design in the Greek Revival style features a ribbed neck with a gadrooned bowl surmounted by a palmette band and an egg and dart rim design. Designed for use in conjunction with the Ionian Jardiniere (see page 40).

Width at top: 500mm (19¾")
Width at base: 270mm (10⅝")
Height: 845mm (33¼")
Weight: 104kg (229 lb)

Recommended pedestals: B255, B265, B331

(Registered Design No. 3010465)



Festooned Vase A285

Designed for use in association with the Festooned Jardiniere (see page 40), this design by Haddonstone can be elevated on a variety of standard pedestals and plinths.

Width at top: 520mm (20½")
Width at base: 280mm (11")
Height: 850mm (33½")
Weight: 115kg (253 lb)

Recommended pedestals: B255, B265, B331

Fontainebleau Urn A300

This elegant urn is a replica of an XVIII century marble original. It is also available as a fountain centrepiece (see C230 on page 96).

Width at top: 915mm (36") Height: 635mm (25")
 Width at base: 470mm (18½") Weight: 166kg (366 lb)

Recommended pedestals: B120, B360

Jubilee Urn A440

To commemorate the occasion of our Silver Jubilee in 1996, Haddonstone produced a Jubilee Urn inspired by James Blashfield's XIX century artificial stone tazza. A special limited edition of twenty-five was launched at the Chelsea Flower Show. A standard edition is now a part of the Haddonstone Collection.

Width at top: 810mm (32") Height: 775mm (29¾")
 Width at base: 330mm (13") Weight: 145kg (319 lb)

Recommended pedestals: B120, B255, B265, B350

(Registered Design No. 2056413)



State Vase with handles A600

State Vase without handles A590 (not illustrated)

This imposing mid-Victorian design has been translated from a cast-iron original and is available with or without handles.

Width at top: 560mm (22")
 Width at base: 300mm (11¾")
 Height: 785mm (31")
 Weight: 81kg (179 lb)

Recommended pedestals: B255, B265, B350, B370

Large Clarence Urn A214

An elegant Regency-style urn, identical in proportion to the Clarence Urn A215, see page 26.

Width at top: 780mm (30¾")
 Width at base: 350mm (13¾")
 Height: 605mm (23¾")
 Weight: 104kg (229 lb)

Recommended pedestals: B255, B265

(Registered Design No. 2083499)

GARDEN & LANDSCAPE PLANTERS - TRADITIONAL



Campana Vase [A212](#)

The campana-shaped bowl features stylised acanthus leaf decoration.

Width at top: 755mm (29³/₄" Height: 1035mm (40³/₄"
Width at base: 460mm (18¹/₈" Weight: 187kg (412 lb)

Recommended pedestal: B120.



Large Versailles Vase [A680](#)

A handsome campana-shaped vase with gadrooning to the bowl. Identical in proportion to Versailles Vase A690, see page 28.

Width at top: 785mm (31" Height: 1065mm (42")
Width at base: 380mm (15" Weight: 179kg (395 lb)

Recommended pedestals: B120, B370

Tatham Tazza Q998

The Coade original for this fine design dates from c1812 and is known as the Tatham Tazza after Charles Heathcote Tatham (1772-1842), an architect of considerable repute who studied in Italy.

Width at top: 890mm (35") Height: 660mm (26")
Width at base: 460mm (18½") Weight: 127kg (280 lb)

Recommended pedestals: B120, B360

Gallé Vase A325

Replicated for the National Trust Ascott Estate, where the originals stand in the Venus Fountain Garden. The bowl of this striking vase has a wide rim and is decorated with a leaf design having strong art-nouveau influences.

Width at top: 850mm (33½") Height: 985mm (38¾")
Width at base: 420mm (16½") Weight: 213kg (470 lb)

Recommended pedestals: B120, B370



Waterloo Urn A750

A large, imposing urn in classical form with deep gadrooning. Stockport Borough Council commissioned Haddonstone to produce a series of Waterloo Urns to line the terraces at Lyme Hall, Cheshire.

Width at top: 785mm (31") Height: 760mm (30")
Width at base: 535mm (21") Weight: 205kg (452 lb)

Recommended pedestal: B120

GARDEN & LANDSCAPE PLANTERS - TRADITIONAL

Plaited Jardiniere A520

This is a replica of an exquisite Victorian jardiniere with a combination of basketwork design to the bowl and leaf moulding to the rim. Neat and compact, it is an immensely versatile piece.

Width at top: 790mm (31")
Width at base: 395mm (15½")
Height: 330mm (13")
Weight: 75kg (162 lb)



Tudor Jardiniere A630

An interwoven strapwork design with rope decoration around the rim and foot. This jardiniere is designed for placing on walls and piers as well as at ground level.

Width at top: 535mm (21")
Width at base: 360mm (14¼")
Height: 380mm (15")
Weight: 38kg (84 lb)

Small Tudor Jardiniere A625

In response to requests from our clients for a smaller jardiniere we introduced this piece to the range which complements the popular original Haddonstone design and is ideal for interior planting in conservatories and garden rooms.

Width at top: 395mm (15½")
Width at base: 245mm (9¾")
Height: 290mm (11½")
Weight: 26kg (57 lb)



Elizabethan Jardiniere A270

A versatile container which complements a traditional or contemporary setting.

Width at top: 660mm (26")
Width at base: 430mm (17")
Height: 470mm (18½")
Weight: 79kg (175 lb)

Small Elizabethan Jardiniere A275

The attractive strapwork decoration on this design complements the popular Elizabethan Jardiniere. Also, the Elizabethan Box (see page 42).

Width at top: 470mm (18½")
Width at base: 300mm (11¾")
Height: 345mm (13⅝")
Weight: 41kg (90 lb)

(Registered Design No. 2074670)



Large Elizabethan Jardiniere

A272

Created following numerous requests from clients, this version of the popular Elizabethan Jardiniere design provides an excellent planting capacity.

Width at top: 825mm (32½")

Width at base: 510mm (20")

Height: 610mm (24")

Weight: 112kg (247 lb)

GARDEN & LANDSCAPE PLANTERS - TRADITIONAL

Herculean Bowl HA385

The Herculean Bowl - an impressively large jardiniere which will make an impact in any setting. The design features festoons of fruit including pears, plums and grapes, bound together with ribbons and swags.

Height: 1000mm (39³/₈"")
 Width overall: 1200mm (47¹/₄"")
 Width at base: 600mm (23⁵/₈"")
 Weight: 340kg (749 lb)

Please note: will require mechanical lifting on site in all instances.



Small Scrolled Jardiniere A575

Haddonstone introduced this jardiniere as a complementary design to the popular Haddonstone Scrolled Jardiniere. Illustrated in our terracotta colour.

Height: 360mm (14¹/₄"")
 Width overall: 440mm (17¹/₄"")
 Width at base: 203mm (8")
 Weight: 46kg (101 lb)

(Registered Design No. 2054077)

Scrolled Jardiniere A580

Taken from a design by Mary Watts (1849-1938) for the Compton Potters' Arts Guild, this simple and attractive jardiniere was previously attributed to Gertrude Jekyll - a great admirer of Mary Watts and her contribution to the Arts and Crafts movement. Shown here in our terracotta colour.

Width at top: 535mm (21")
 Width overall: 595mm (23¹/₂"")
 Width at base: 280mm (11")
 Height: 485mm (19")
 Weight: 95kg (209 lb)



Small Roman Jardiniere A534

Simple lines and good proportions are the features of this Haddonstone design, which is ideal for topiary box or bay.

Height: 380mm (15")
 Width overall: 430mm (17")
 Width at base: 203mm (8")
 Weight: 55kg (121 lb)

Roman Jardiniere A535

Identical in proportion to the Small Roman Jardiniere. Suitable for either traditional or contemporary gardens and landscapes.

Height: 515mm (20¹/₄"")
 Width overall: 565mm (22¹/₄"")
 Width at base: 280mm (11")
 Weight: 109kg (240 lb)

Spartan Bowl HA615

Adapted from the Herculean Bowl, this massive planter features elegant lines and bold mouldings.

Height: 1000mm (39³/₈"")
 Width overall: 1200mm (47¹/₄"")
 Width at base: 600mm (23⁵/₈"")
 Weight: 340kg (749 lb)

Please note: will require mechanical lifting on site in all instances.



Roman Vase TLHA540

This Italian vase with simple circular mouldings is suitable for large and small plantings. Illustrated in our terracotta colour.

Width at top: 610mm (24")
 Width at base: 265mm (10¹/₂"")
 Height: 485mm (19")
 Weight: 38kg (84 lb)



Large Roman Vase TLHA545

Complementing the standard Roman Vase is this taller example, which also features simple circular mouldings. Illustrated in our terracotta colour.

Width at top: 790mm (31")
 Width at base: 390mm (15¹/₂"")
 Height: 815mm (32")
 Weight: 110kg (242 lb)



Compton Bowl A225

Suitable for either traditional or contemporary gardens, this simple and attractive bowl is adapted from the Poppy Bowl, based upon a design by Mary Watts (1849-1938) for the Compton Potters' Arts Guild.

Width at top: 710mm (28")
 Width at base: 320mm (12¹/₂"")
 Height: 535mm (21")
 Weight: 94kg (207 lb)

Poppy Bowl A525

Based upon a design by Mary Watts (1849-1938) for the Compton Potters' Arts Guild, this versatile bowl is ideal for terraces and patios. This design reflects the style of the Arts and Crafts movement.

Width at top: 710mm (28")
 Width at base: 320mm (12¹/₂"")
 Height: 535mm (21")
 Weight: 100kg (220 lb)

GARDEN & LANDSCAPE PLANTERS - TRADITIONAL

Large Gothic Basket A335

The new Large Gothic Basket design is a taller version of Haddonstone's popular Gothic Basket. First created as a bespoke design for a private client, this planter is ideal for enhancing terraces, patios and garden rooms.

Height: 647mm (25½")
Width at top: 762mm (30")
Width at base: 450mm (17¾")
Weight: 145kg (319 lb)



Ionian Smokers' Stand HA424S

An elegant design adapted from the Ionian Jardiniere (see right) for use by hotels, restaurants and retail premises. Features a removable stainless steel sleeve for cleaning. Suitable for both interiors and exteriors.

Width of top: 500mm (19¾")
Height: 510mm (20⅙")
Weight: 106kg (233 lb)

(Registered Design No. 3010464)

Ionian Jardiniere A424

This design has been created by Haddonstone in the Greek Revival style. The jardiniere features a palmette around a cylindrical form and has been designed for use in conjunction with the Ionian Vase (see page 32).

Width at top: 500mm (19¾")
Height: 510mm (20⅙")
Weight: 93kg (205 lb)

Festooned Jardiniere A284

A bold design created by Haddonstone featuring festoons of fruit bound together with ribbons in the classical style. Designed for use in conjunction with the Festooned Vase (see page 32).

Width at top: 520mm (20½")
Width at base: 400mm (15¾")
Height: 565mm (22¼")
Weight: 84kg (185 lb)

Gothic Basket A330

A neo-Gothic-style basket with interlaced strapwork and acanthus-leaf moulding around the base. The rim is decorated with leaf and ribbon moulding.

Width at top: 622mm (24½")
Width at base: 387mm (15¼")
Height: 413mm (16¼")
Weight: 56kg (123 lb)

(Registered Design No. 1059496)

Kensington Bowl

A450

This large and versatile twelve-sided planter features an entwined hop design around the bowl.

Width: 735mm (29")
Height: 405mm (16")

Diameter at base: 455mm (18")
Weight: 102kg (226 lb)



Marlborough Bowl

A495

In the style of a Greek kylix, this elegant bowl is a Haddonstone design featuring a square base with gadrooning to the bowl.

Height: 365mm (14³/₈"")
Width overall: 600mm (23⁵/₈"")
Width at base: 330mm (13")
Weight: 72kg (159 lb)

Recommended pedestals:
B255, B265, B350.



Byzantine Bowl

A210

Replicated from a Verona marble bowl of Byzantine design. Within foliate borders, it is decorated with four oval panels featuring stylised mythological creatures. These panels are divided by ornate strapwork.

Width: 530mm (21")
Height: 440mm (17¹/₂"")
Diameter at base: 280 mm (11")
Weight: 78kg (172 lb)



Romanesque Bowl

TLHA550

An extremely useful bowl featuring Romanesque coin-moulding motifs in a band around the rim. It is also available as a freestanding fountain (see page 104, TLHC521).

Diameter: 815mm (32")
Width at base: 435mm (17¹/₈"")
Height: 330mm (13")
Weight: 62kg (137 lb)

Plaited Basket A510

A delightful oval basket with plaited rim. See also, the Plaited Trough A515, page 48.

Length: 510mm (20")
Width: 395mm (15½")
Height: 215mm (8½")
Weight: 17kg (37 lb)



Haddonstone Box A400

A design composed of bouquets of flowers with ribbon and knot detail.

Width: 420mm (16½")
Height: 420mm (16½")
Weight: 71kg (156 lb)



Belton Box A195

A small planting box in Victorian style having a basketwork design of rod and ribbon to all sides. Ideal as a planter for wall tops, steps, or either side of an entrance doorway. The design complements that of our Belton Troughs (see page 48).

Width at top: 330mm (13")
Width at base: 165mm (6½")
Height: 260mm (10¼")
Weight: 18kg (40 lb)

Elizabethan Box A265

An alternative shape designed to complement our Small Elizabethan Jardiniere (see page 36) with the attractive strapwork decoration that has become so popular.

Width at top: 470mm (18½")
Width at base: 300mm (11¾")
Height: 345mm (13⅝")
Weight: 49kg (108 lb)

Maidford Bowl A480

This versatile design by Haddonstone, in the style of James Gibbs, has a fluted bowl with stylised leaf moulding to the rim and base. Named after the Manorial Lordship of Maidford Halse in Northamptonshire.

Width overall: 600mm (23⅝")
Height: 280mm (11")
Width at base: 343mm (13½")
Weight: 46kg (101 lb)

GARDEN & LANDSCAPE PLANTERS - TRADITIONAL

Large Italian Jardiniere HA435

This large jardiniere complements the popular existing Italian Jardiniere designs.

Width at top: 1015mm (40")
Width at base: 790mm (31½")
Height: 760mm (30")
Weight: 400kg (881 lb)

(Registered Design No. 2061157)

Please note: will require mechanical lifting on site in all instances.



Italian Jardiniere A430

A versatile jardiniere with reticulated rose and rod decoration with rope moulding around the rim and foot.

Width at top: 630mm (24¾")
Width at base: 495mm (19½")
Height: 405mm (16")
Weight: 73kg (161 lb)



Italian Quadrant Planter (1 section) A431

The Italian Quadrant Planter provides a solution to the problem of how to ornament a difficult corner. Decorated on one side, yet plain on the other two faces, the planter can be: positioned in a corner; two can be placed side by side to create a wall trough; three can wrap round a corner; whilst four can create a compartmentalised planter ideal for containing invasive plants or herbs.



Italian Quadrant Planter (2 section) A432



Italian Quadrant Planter (3 section) A433



Italian Quadrant Planter (4 section) A434

Top radius: 500mm (19¾")
Base radius: 415mm (16⅜")
Height: 515mm (20¼")
Weight (per section): 73kg (161 lb)



Andalos Jardiniere A150

An Arabesque design. The twelve-sided bowl displays an hexagonal decoration, whilst the hexagonal base features a twelve-sided decoration. Also available is the freestanding Andalos Fountain C100, see page 106.

Width at rim: 725mm (28½")

Width at base: 560mm (22")

Height: 770mm (30¼")

Weight: 171kg (377 lb)

Corredo Jardiniere A230

Corredo Jardiniere Plinth A240

The original of this imposing Italian planter bearing two armorial devices was probably a dowry gift in the XVI century. A plinth is available.

Jardiniere width: 860mm (33¾")

Jardiniere weight: 153kg (337 lb)

Jardiniere base: 450mm (17¾")

Plinth weight: 77kg (170 lb)

Jardiniere height: 635mm (25")

Plinth width: 660mm (26")

Plinth height: 172mm (6¾")



Large Gothic Jardiniere HA345

Large Gothic Upper Base HA355 (in 8 sections)

This imposing jardiniere and base has been created to meet clients' requests for a larger version of the popular Gothic Jardiniere. The octagonal design incorporates double-quatrefoil panels on each face. The Upper Base fits around the Jardiniere, making the overall height of the ensemble 1190mm (46⁷/₈").

Overall width of jardiniere: 1252mm (49¹/₄")

Overall width of jardiniere base: 966mm (38")

Height of jardiniere: 1190mm (46⁷/₈")

Weight of jardiniere: 1336kg (2943 lb)

Overall width of base: 1998mm (78⁹/₁₆")

Height of base: 160mm (6¹/₄")

Weight of base: 302kg (664 lb)

Please note: will require mechanical lifting on site in all instances.

Gothic Jardiniere

A340

Upper Base A350

Lower Base A360

A Regency Gothic octagonal jardiniere with double-quatrefoil panels. It has alternate acanthus and rose relief bosses. Shown on an Upper Base in four sections. For Lower Base in eight sections see diagram. It is also available as a freestanding fountain (see page 106, C251).

It is essential that your Gothic Jardiniere and bases are sited on a firm and level area. An 8 to 1 sand/cement bedding mortar should be used to ensure that the weight of the Jardiniere and bases is spread evenly, avoiding any pivoting or twisting strain. We cannot accept responsibility for cracking or breakage if this instruction is ignored.

Weight of jardiniere:

224kg (494 lb)

Weight of Upper Base:

128kg (282 lb)

Weight of Lower Base:

342kg (754 lb)

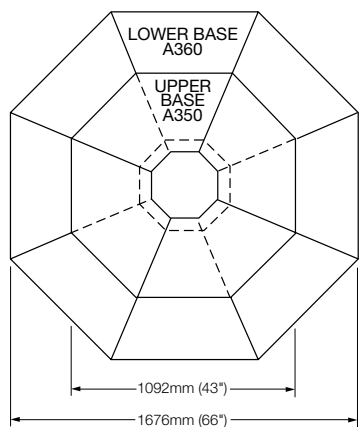
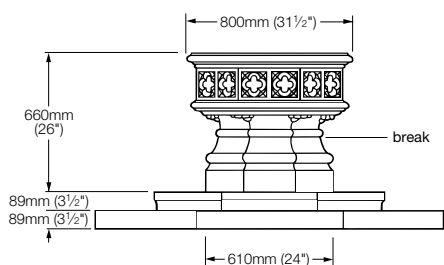



Victorian Jardiniere A710

Upper Plinth [A720](#)

Lower Plinth [A730](#)

inspired by an Austin & Seeley design, this imposing ensemble is an elegant example of the XIX century naturalist style of ornament. The surprising combination of basketwork and dragon's feet is characteristic of this style. These jardiniere are used by the Royal Horticultural Society at Wisley. See diagrams below for dimensions.

Jardiniere weight: 205kg (452 lb)
 A720 plinth weight: 86kg (190 lb)
 A730 plinth weight: 118kg (260 lb)
 Ensemble weight: 409kg (902 lb)

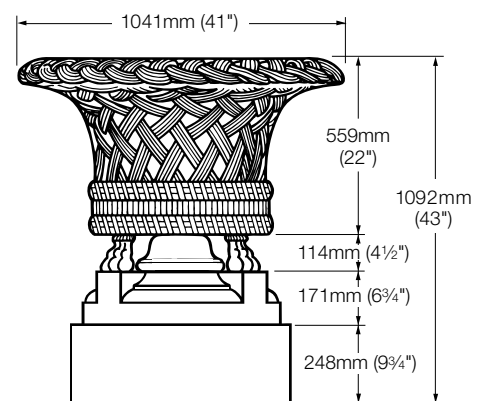

Victorian Jardiniere A710
with A720 and A730 Plinths.

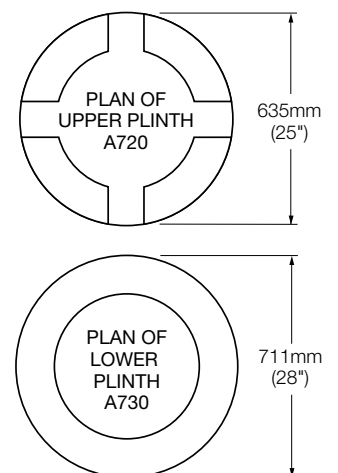

It is essential that the Victorian Jardiniere and plinths are sited on a firm and level area. An 8-1 sand/cement bedding mortar should be used to ensure that the weight of the jardiniere and bases is spread evenly, avoiding any pivoting or twisting strain. We cannot accept responsibility for cracking or breakage if this instruction is ignored.

Well Head [C600](#)

This highly decorative well head takes the form of a Corinthian capital. Shown with Overthrow WA900 by Haddoncraft Forge.

Width at top: 1000mm (39¼")
 Width at base: 850mm (33½")
 Height: 900mm (35½")
 Weight: 352kg (776 lb)



Victorian Jardiniere A710
Upper Plinth A720
Lower Plinth A730

GARDEN & LANDSCAPE PLANTERS - TRADITIONAL

Victorian Trough and Support A735

The design of this charming rectangular trough, taken from a Vicenza stone original, is embellished with festoons of ribbon-tied roses and acanthus leaves, with gadrooning to the rim.

Length: 650mm (25¾")
Width: 370mm (14½")

Height: 395mm (15¾")
Weight: 73kg (160 lb)



Belton Wall Trough A200

A simple Victorian basketweave design with rod and ribbon detailing and a plain back. Can be used as a window box. The design complements the Belton Box, see page 42.

Length: 865mm (34")
Width: 305mm (12")
Height: 260mm (10¼")
Weight: 50kg (110 lb)



Belton Trough A190

A variation of the Belton Wall Trough with rod and ribbon detailing to all sides. The design complements the Belton Box, see page 30.

Length: 865mm (34")
Width: 380mm (15")
Height: 260mm (10¼")
Weight: 55kg (121 lb)



Plaited Trough A515

Complementing the Plaited Basket A510 (see page 30), this basketweave design is ideal for low walls and terraces.

Length: 770mm (30¼")
Width: 395mm (15½")

Height: 215mm (8½")
Weight: 32kg (70 lb)

Venetian Trough A650 Fluted Supports A670

Reproduced from an original XV century Venetian design, this trough looks attractive when elevated on supports and placed against a wall.

Length: 1170mm (46") Height of supports: 395mm (15½")
 Width: 385mm (15½") Weight of trough: 153kg (337 lb)
 Height of trough only: 400mm (15¾") Weight of each support: 35kg (77 lb)



Adam Trough A110 Adam Supports A120

This Adam-style trough, adorned with festoons and medallions, is ideal for decorating terraces or porches. For Adam Box, see below.

Length: 1220mm (48") Height of supports: 140mm (5½")
 Width: 345mm (13½") Weight of trough: 176kg (388 lb)
 Height of trough only: 355mm (14") Weight of each support: 11kg (25 lb)



Adam Box A100

An Adam-style container decorated with festoons and medallions, ideal for use on walls or terraces. For Adam Trough, see above.

Length: 610mm (24")
 Width: 305mm (12")
 Height: 380mm (15")
 Weight: 55kg (121 lb)



Arabesque Trough A160 Arabesque Supports A170

Arabesque-style trough featuring an interlaced flower and leaf pattern set in banded panels. Can be raised on supports if desired.

Length: 1015mm (40")
 Width: 345mm (13½")
 Height of trough only: 355mm (14")
 Height of supports: 127mm (5")
 Weight of trough: 112kg (247 lb)
 Weight of each support: 10kg (22 lb)

GARDEN & LANDSCAPE PLANTERS - TRADITIONAL

Roman Trough A555

This stylish trough with a strigillated design has been created by Haddonstone for use in both traditional and contemporary schemes.

Length: 1100mm (43⁵/₈"")
Width: 400mm (15¹/₄"")
Height: 380mm (15")
Weight: 156kg (344 lb)

(Registered Design No. 2056402)



Small Alpine Trough A140 (not illustrated)

This rustic trough is an ideal container for a miniature alpine garden.

Length: 850mm (33¹/₂"")
Width: 560mm (22")
Height: 255mm (10")
Weight: 102kg (224 lb)

Large Alpine Trough A130

The Large Alpine Trough is much sought after by alpine specialists.

Length: 1090mm (43")
Width: 660mm (26")
Height: 280mm (11")
Weight: 156kg (344 lb)



Promenade Trough HA527

Featuring an impressive planting area, the rectangular Promenade Trough is ideal for large landscape schemes. It is possible to cast lettering or dates into this trough during production. Please ask for details. See also, Promenade Box page 13.

Length: 1588mm (62¹/₂"") Height: 597mm (23¹/₂"")
Width: 717mm (28¹/₄"") Weight: 636kg (1400 lb)

Please note: will require mechanical lifting on site in all instances.

GARDEN & LANDSCAPE PLANTERS - CONTEMPORARY

Haddonstone, long associated with classical and traditional design, is now also renowned for contemporary style. The Art Deco and Cubist inspired planters on the following pages first brought Haddonstone's Modernist designs to the fore. Most feature geometric patterns and all are suitable for either residential or commercial projects.

Large Key HA955

Width: 500mm (19³/₄"")
Height: 510mm (20¹/₄"")
Weight: 156kg (344 lb)

Key TLHA950

Width: 305mm (12")
Height: 305mm (12")
Weight: 20kg (44lb)



Block TLHA915

Width: 305mm (12")
Height: 305mm (12")
Weight: 20kg (44 lb)



Puzzle TLHA965

Width: 305mm (12")
Height: 305mm (12")
Weight: 20kg (44 lb)



Rib TLHA970

Width: 305mm (12")
Height: 305mm (12")
Weight: 20kg (44 lb)



Strap TLHA975

Width: 305mm (12")
Height: 305mm (12")
Weight: 20kg (44 lb)



Small Puzzle TLHA966

Small Key TLHA951

Small Rib TLHA971

Width: 100mm (4")
Height: 112mm (4¹/₂"")
Weight (each): 1kg (2lb 3oz)

GARDEN & LANDSCAPE PLANTERS - CONTEMPORARY

Classic TLHA930

Width at top: 650mm (25⁵/₈"")
Width at base: 355mm (14")
Height: 545mm (21¹/₂"")
Weight: 55kg (121 lb)



Cube TLHA935

Width: 420mm (16¹/₂"")
Height: 420mm (16¹/₂"")
Weight: 46kg (101 lb)



Meander TLHA960

Width: 420mm (16¹/₂"")
Height: 420mm (16¹/₂"")
Weight: 51kg (112 lb)



Arc TLHA900

Width: 420mm (16¹/₂"")
Height: 430mm (16¹⁵/₁₆"")
Weight: 54kg (119 lb)



Crucible HA910

Crucible Fountain also available,
see page 107.

Width: 500mm (19³/₄"")
Height: 620mm (24³/₈"")
Weight: 102kg (225 lb)



Sunburst
HA980

Width: 450mm (17³/₄"")
Height: 545mm (21¹/₂"")
Weight: 140kg (308 lb)



Flute
HA940

Width at top: 600mm (23³/₄"")
Width at base: 340mm (13³/₈"")
Height: 660mm (26")
Weight: 141kg (311 lb)

Chalice
HA920

Width: 420mm (16¹/₂"")
Height: 840mm (33¹/₁₆"")
Weight: 158kg (348 lb)



Large Highland Park Fire Pit HA413 (USA only)

The Large Highland Fire Pit is an innovation from Haddonstone (USA) Ltd. Ideal for yards and terraces, the Fire Pit provides a unique focal point – and warmth as the sun goes down! Available in both manual and automatic versions. Black firecrystals not supplied.

Width at top: 40"
 Width at base: 32"
 Height: 17"
 Weight: 432 lb



Design: Mark Salzman

Large Highland Park Planter A414

Width at top: 1016mm (40")
 Width at base: 812mm (32")
 Height: 430mm (17")
 Weight: 182kg (400 lb)

Small Highland Park Planter A415

Width at top: 762mm (30")
 Width at base: 635mm (25")
 Height: 355mm (14")
 Weight: 86kg (190 lb)



Small Octagonal Jardiniere HA503 Medium Octagonal Jardiniere HA504

Featuring bold ogee mouldings, these jardiniere complement the Large Octagonal Jardiniere, see right.

Small Octagonal Jardiniere

Maximum width face to face: 615mm (24 1/4")
 Height: 390mm (15 3/8")
 Weight: 140kg (308 lb)

Medium Octagonal Jardiniere

Maximum width face to face: 1010mm (39 3/4")
 Height: 635mm (25")
 Weight: 450kg (991 lb)

Please note: will require mechanical lifting on site in all instances.



Bay Planter HA185

The stylish Bay Planter is a new addition to the Haddonstone Collection. Also available as a self-circulating fountain, see page 106.

Height: 400mm (15³/₄"")
 Width at top: 1850mm (72⁷/₈"")
 Weight: 690kg (1520 lb)



Small Lagoon Planter HA460 (not illustrated) Lagoon Planter HA463 Large Lagoon Planter HA465 (not illustrated)

These designs also available as self-circulating fountains, see page 104.

	HA460	HA463	HA465
Height:	600mm (23 ⁵ / ₈ "")	600mm (23 ⁵ / ₈ "")	600mm (23 ⁵ / ₈ "")
Top width:	1220mm (48")	1570mm (61 ³ / ₄ "")	1775mm (69 ⁷ / ₈ "")
Weight:	535kg (1178 lb)	857kg (1888 lb)	1092kg (2405 lb)

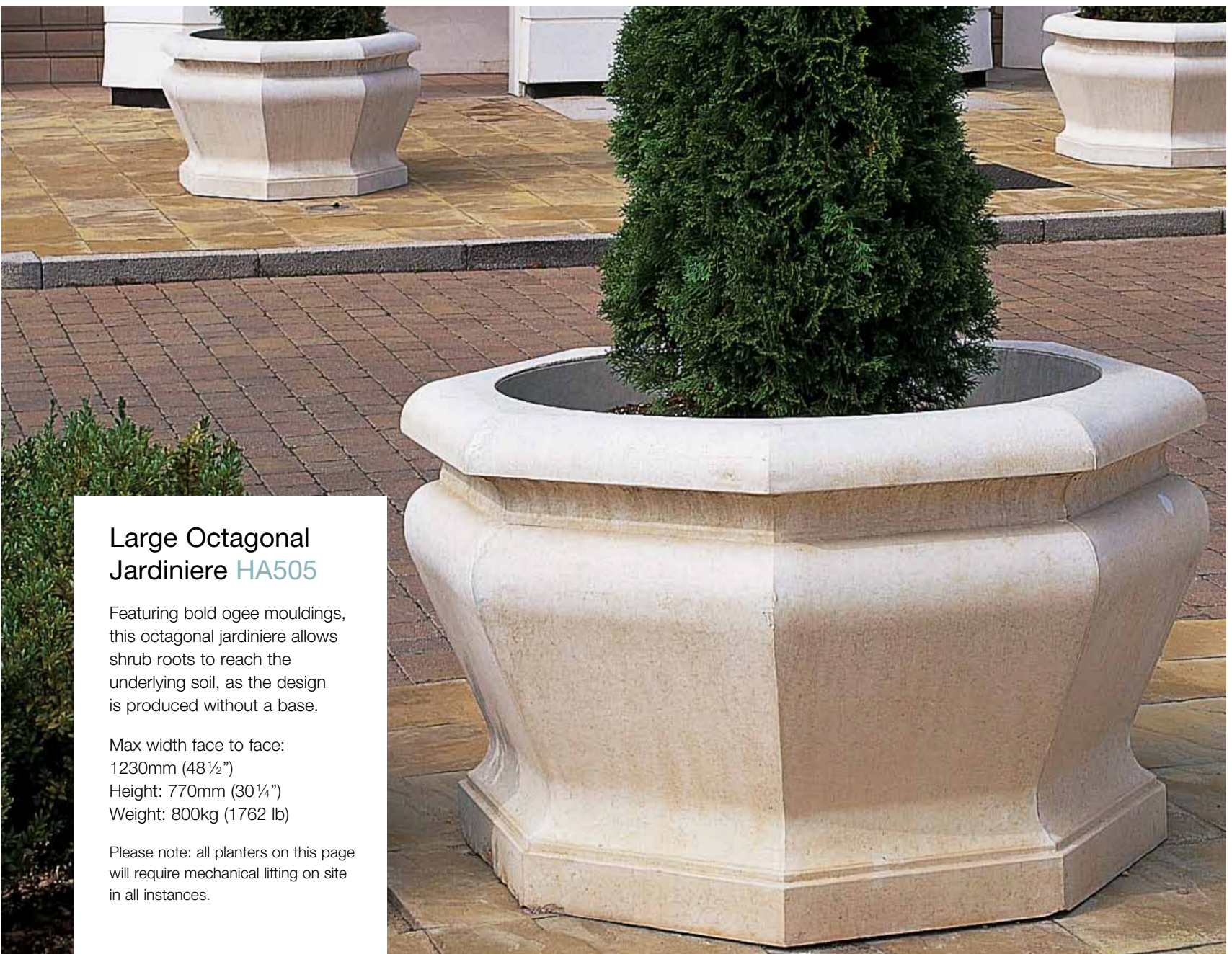

Large Octagonal Jardiniere HA505

Featuring bold ogee mouldings, this octagonal jardiniere allows shrub roots to reach the underlying soil, as the design is produced without a base.

Max width face to face:
 1230mm (48¹/₂"")
 Height: 770mm (30¹/₄"")
 Weight: 800kg (1762 lb)

Please note: all planters on this page will require mechanical lifting on site in all instances.

GARDEN & LANDSCAPE PLANTERS - CONTEMPORARY

The Robert A.M. Stern Collection

Robert A.M. Stern is the founding partner of the architectural firm that bears his name. The firm has an international reputation as a leading design practice with wide experience in residential, commercial, office, hospitality, healthcare and institutional work. Attention to detail and a commitment to design quality has resulted in the creation of the Robert A.M. Stern Collection comprising a wide range of interior

and exterior products. Each partner company has been identified as a market-leader with a reputation for outstanding design, superb performance and unparalleled customer service. Haddonstone is proud to have been selected on this basis. The first planter and pedestal designs from the resultant collection are shown on these pages.



Olympian Vase A911

Maximum width: 413mm (16 1/4")
Width at base: 300mm (11 13/16")
Height: 914mm (36")
Weight: 110kg (242 lb)

Small Olympian Bowl A915 Excludes B332 Pedestal

Maximum width: 630mm (24 13/16")
Width at base: 292mm (11 1/2")
Height: 324mm (12 3/4")
Weight: 60kg (131 lb)
Recommended Stern pedestals:
B940, B950.

Small Olympian Urn A913 Excludes B332 Pedestal

Maximum width: 505mm (19 7/8")
Width at base: 286mm (11 1/4")
Height: 526mm (20 3/4")
Weight: 60kg (131 lb)
Recommended Stern pedestals:
B940, B950.

Olympian Urn A912

Maximum width: 760mm (29 15/16")
Width at base: 410mm (16 1/8")
Height: 784mm (30 7/8")
Weight: 198kg (435 lb)
Recommended Stern pedestal: B930.

Olympian Bowl A914

Maximum width: 945mm (37 1/4")
Width at base: 420mm (16 1/2")
Height: 480mm (18 7/8")
Weight: 152kg (335 lb)
Recommended Stern pedestal: B930.

Athenian Urn

A923 Excludes B332 Pedestal

Width at top: 760mm (29⁵/₁₆"")

Width at base: 308mm (12¹/₈"")

Height: 622mm (24¹/₂"")

Weight: 87kg (192 lb)

Recommended Stern pedestal: B920.

Small Athenian Bowl

A926 Excludes B332 Pedestal

Width at top: 750mm (29¹/₂"")

Width at base: 230mm (9¹/₁₆"")

Height: 340mm (13³/₈"")

Weight: 43kg (95 lb)

Recommended Stern pedestal: B900.

Small Athenian Vase

A922 Excludes B332 Pedestal

Width at top: 420mm (16¹/₂"")

Width at base: 190mm (7¹/₂"")

Height: 527mm (20³/₄"")

Weight: 28kg (62 lb)

Recommended Stern pedestal: B900.



Athenian Vase

A921

Width at top: 625mm (24⁵/₈"")

Width at base: 308mm (12¹/₈"")

Height: 790mm (31¹/₈"")

Weight: 96kg (211 lb)

Recommended Stern pedestal: B920.

Athenian Bowl

A925

Width at top: 866mm (34¹/₈"")

Width at base: 308mm (12¹/₈"")

Height: 418mm (16¹/₂"")

Weight: 62kg (135 lb)

Recommended Stern pedestal: B920.

Small Athenian Urn

A924

Width at top: 568mm (22³/₈"")

Width at base: 230mm (9¹/₁₆"")

Height: 467mm (18³/₈"")

Weight: 43kg (95 lb)

Recommended Stern pedestal: B910.

Athenian Vase

A927

Incorporating scrolled foot

Width at top: 625mm (24⁵/₈"")

Width at base: 396mm (15⁹/₁₆"")

Height: 764mm (30¹/₈"")

Weight: 96kg (211 lb)

GARDEN & LANDSCAPE PEDESTALS AND PLINTHS

IMPORTANT PEDESTAL SITING It is essential that your Haddonstone pedestal is sited on a firm and level area to suit site conditions and loadings. An 8 to 1 sand/cement bedding mortar should be used to ensure that the weight of the pedestal and urn is spread evenly across the base of the pedestal, avoiding any pivoting or twisting strain. We cannot accept responsibility for cracking or breakage if this instruction is ignored. Technical Sheets available for all Athenian and Olympian pedestals.



48" Olympian Pedestal B950

Shown with
Small Olympian Bowl A915

Width at top: 330mm (13")
Width at base: 508mm (20")
Height: 1219mm (48")
Weight: 113kg (249 lb)

40" Olympian Pedestal B940

Shown with
Small Olympian Urn A913

Width at top: 356mm (14")
Width at base: 508mm (20")
Height: 1016mm (40")
Weight: 120kg (264 lb)

32" Athenian Pedestal B920

Shown with
Athenian Bowl A925

Width at top: 356mm (14")
Width at base: 611mm (24")
Height: 815mm (32½")
Weight: 140kg (308 lb)

32" Olympian Pedestal B930

Shown with
Olympian Bowl A914

Width at top: 507mm (20")
Width at base: 610mm (24")
Height: 813mm (32")
Weight: 163kg (359 lb)

38" Slender Athenian Pedestal B900

Shown with
Small Athenian Vase A922

Width at top: 216mm (8½")
Width at base: 409mm (16⅛")
Height: 968mm (38⅛")
Weight: 83kg (183 lb)

38" Athenian Pedestal B910

Shown with
Small Athenian Urn A924

Width at top: 275mm (10⅞")
Width at base: 520mm (20½")
Height: 968mm (38⅛")
Weight: 114kg (251 lb)



**42" Athenian
Classic Pedestal**

B901

Shown with
Caesar Augustus HE815

Width at top: 255mm (10")
Width at base: 409mm (16 $\frac{1}{8}$ ")
Overall Height: 1066mm (42")
Weight: 93kg (205 lb)

**36" Athenian
Classic Pedestal**

B921

Shown with
Ionian Vase A425

Width at top: 395mm (15 $\frac{1}{2}$ ")
Width at base: 611mm (24")
Overall Height: 920mm (36 $\frac{1}{4}$ ")
Weight: 168kg (370 lb)

**43" Athenian
Classic Pedestal**

B911

Shown with
Versailles Vase A690

Width at top: 324mm (12 $\frac{3}{4}$ ")
Width at base: 520mm (20 $\frac{1}{2}$ ")
Overall Height: 1085mm (42 $\frac{3}{4}$ ")
Weight: 133kg (293 lb)



B370 Pedestal
(Shown with
Eastwell Urn)

B360 Pedestal
(Shown with
Fontainebleau Urn)

B350 Pedestal
(Shown with
Florentine Urn)

B120 Pedestal
(Shown with
Large Versailles Vase)

B265 Pedestal
(Shown with
State Vase)

B255 Pedestal
(Shown with
Westonbirt Urn)

Dado Pedestal B370 & HB370

Classical column pedestal design with deep recessed compound moulding.

Width at base: 457mm (18")
Height: 279mm (11")
Weight: 61kg (134 lb)

IMPORTANT PEDESTAL SITING

It is essential that your Haddonstone pedestal is sited on a firm and level area to suit site conditions and loadings. An 8 to 1 sand/cement bedding mortar should be used to ensure that the weight of the pedestal and urn is spread evenly across the base of the pedestal, avoiding any pivoting or twisting strain. We cannot accept responsibility for cracking or breakage if this instruction is ignored.

Large Winslow Pedestal B360

Large pedestal, identical in proportion to the Winslow Pedestal B350, below. For use with larger urns and vases.

Width at base: 750mm (29½")
Width at top: 508mm (20")
Height: 293mm (11½")
Weight: 212kg (467 lb)

Winslow Pedestal B350

Robustly moulded pedestal, ideal for raising urns and vases slightly above ground level.

Width at base: 525mm (20¾")
Width at top: 355mm (14")
Height: 205mm (8")
Weight: 57kg (125 lb)

Georgian Pedestal B120

Imposing pedestal with deep recessed compound mouldings.

Width at base: 700mm (27½")
Width at cap: 735mm (29")
Width of block: 546mm (21½")
Height (inc. block): 908mm (35¾")
Weight: 389kg (857 lb)

36"Queen Anne Pedestal B265

Pedestal featuring a deeply fielded panel to the pedestal shaft.

Cap and base width: 485mm (19")
Height: 915mm (36")
Weight: 170kg (375 lb)

27"Queen Anne Pedestal B255

Pedestal featuring a deeply fielded panel to the pedestal shaft.

Cap and base width: 485mm (19")
Height: 685mm (27")
Weight: 153kg (337 lb)



B310 Plinth
(Shown with
Regency Urn)

B300 Plinth
(Shown with
House of
Dun Urn)

B400 Plinth
(Shown with
Wilton Urn)

B420 Plinth
(Shown with
Clarence Urn)

B440 Plinth
(Shown with
Trafalgar Urn)

B480
Pedestal
(Shown with
Etruscan
Vase)

B330
Pedestal
(Shown with
Shugborough
Vase)

B331
Pedestal
(Shown with
Cliveden
Vase)

B130
Pedestal
(Shown with
Vine Urn)

30" Queen Anne Plinth **B310**

Queen Anne-period fielded plinth with plain mouldings around cap and base.

Width at cap: 329mm (12¹⁵/₁₆"")
Width at base: 337mm (13¹/₄"")
Height: 775mm (30¹/₂"")
Weight: 87kg (192 lb)

27" Queen Anne Plinth **B300**

Queen Anne-period fielded plinth with plain mouldings around cap and base.

Width at cap: 329mm (12¹⁵/₁₆"")
Width at base: 337mm (13¹/₄"")
Height: 695mm (27¹/₂"")
Weight: 77kg (170 lb)

20" Elizabethan Plinth **B400**

Featuring a moulded cap.

Width at cap: 377mm (14⁷/₈"")
Width at base: 337mm (13¹/₄"")
Height: 499mm (20")
Weight: 73kg (161 lb)

28" Elizabethan Plinth **B420**

Featuring a moulded cap.

Width at cap: 377mm (14⁷/₈"")
Width at base: 337mm (13¹/₄"")
Height: 721mm (28")
Weight: 79kg (174 lb)

31" Elizabethan Plinth **B440**

Featuring a moulded cap.

Width at cap: 377mm (14⁷/₈"")
Width at base: 337mm (13¹/₄"")
Height: 798mm (31")
Weight: 90kg (198 lb)

Raphael Pedestal **B480**

Small pedestal in high Renaissance style has richly decorated panels on each of four faces. The cap and base have bead and reel ornamentation.

Width at base: 265mm (10¹/₂"")
Cap top width: 235mm (9¹/₄"")
Overall height: 670mm (26¹/₂"")
Weight: 74kg (163 lb)

(Registered Design No.2038958)

Regency Pedestal **B330**

Width at top: 220mm (8³/₄"")
Width at base: 280mm (11")
Height: 430mm (17")
Weight: 33kg (73 lb)

Large Regency Pedestal **B331**

Width at top: 305mm (12")
Width at base: 355mm (14")
Height: 455mm (18")
Weight: 80kg (176 lb)

Gothic Pedestal **B130**

Cap top width: 200mm (7⁷/₈"")
Width at base: 292mm (11¹/₂"")
Height: 774mm (30¹/₂"")
Weight: 76kg (167 lb)

GARDEN & LANDSCAPE PEDESTALS AND PLINTHS

IMPORTANT PEDESTAL SITING

It is essential that your Haddonstone pedestal is sited on a firm and level area to suit site conditions and loadings. An 8 to 1 sand/cement bedding mortar should be used to ensure that the weight of the pedestal and urn is spread evenly across the base of the pedestal, avoiding any pivoting or twisting strain. We cannot accept responsibility for cracking or breakage if this instruction is ignored.



Tuscan Pedestal B170
(Shown with Apollo)



B490 Pedestal
(Shown with
Helena)

B495 Pedestal
(Shown with
Bust of Pan)

B100
Pedestal
(Shown with
Bacchante)

B150 Pedestal
(Shown with
antique lead
figure)

B140
Pedestal
(Shown with
Brutus)

B340 Pedestal
(Shown with
Andromeda)

B335 Pedestal
(Shown with
Venus)

Tuscan Pedestal B170

Width at top: 350mm (13³/₄"")
Width at foot: 406mm (16")
Height: 1054mm (41¹/₂"")
Weight: 145kg (319 lb)

Adam Pedestal B490

Width at base: 358mm (14")
Width at top: 345mm (13⁵/₁₆"")
Height: 887mm (35")
Weight: 103kg (227 lb)
(Registered Design No. 2038747)

Adam Pedestal B495

Width at base: 358mm (14")
Width at top: 345mm (13⁵/₁₆"")
Height: 1087mm (42³/₄"")
Weight: 123kg (271 lb)
(Registered Design No. 2038747)

Doric Pedestal B100

Width at top: 350mm (13³/₄"")
Width at foot: 445mm (17¹/₂"")
Height: 1190mm (46³/₄"")
Weight: 137kg (302 lb)

Jacobean Pedestal B150

Width at base: 385mm (15¹/₄"")
Width at top: 360mm (14³/₁₆"")
Height: 620mm (24¹/₂"")
Weight: 121kg (267 lb)

Ionic Pedestal B140

Width at top: 345mm (13⁵/₁₆"")
Width at foot: 400mm (15³/₄"")
Height: 1140mm (45")
Weight: 136kg (300 lb)

Octagonal Pedestal B340

Width at top: 425mm (16³/₄"")
Height: 380mm (15")
Width overall: 485mm (19")
Face to face: 450mm (17³/₄"")
Weight: 108kg (238 lb)

Small Octagonal Pedestal B335

Width at top: 375mm (14³/₄"")
Height: 310mm (12¹/₄"")
Width overall: 435mm (17")
Face to face: 400mm (15³/₄"")
Weight: 81kg (179 lb)

GARDEN & LANDSCAPE SUNDIALS

DAVIDHARBER

Crescent Sundial X712

Designed and created for Haddonstone by the world-renowned David Harber workshop. The Crescent holds the gnomon, which casts a shadow onto the hour band. Engraved along the hour band is the Latin inscription "HORA QUASI UMBRA" which translates as "time is but a shadow". Manufactured in high specification mirror polished stainless steel, the sundial is ideal for Haddonstone's Baluster Sundial Plinth D145 (not included - see below), or Georgian Sundial Plinth D265 (not included - see right).

Width at base: 215mm (8½") Weight 3.2kg (7 lb)
Height: 280mm (11")



Arcadian Wall Sundial GD360

Includes gnomon. Designed for south facing walls, this decorative ornament gives an insight into the workings of a wall sundial.

Height: 450mm (17¾")
Depth: 30mm (1⅜")
Width: 340mm (13⅜")
Weight: 9kg (20 lb)



Georgian Sundial Plinth D265 (Shown above with Crescent Sundial X712)

A beautiful baluster sundial, after James Gibbs. For Bird Bath, see page 68.

Table Diameter: 335mm (13¼")
Width of base: 335mm (13¼")
Height: 845mm (33¼")
Weight: 73kg (161 lb)
(Registered Design No 2030286)

Baluster Sundial Plinth D145

See left. For dimensions, see Baluster Sundial D140 on page 64.
(Registered Design No. 2030823)

Note: Plinths and dials are priced separately – see price list.

TS Tech Sheet No. M55 TS Tech Sheet No. GAR4 Security Fixings
TS Tech Sheet No. GAR5 Handling Instructions

GARDEN & LANDSCAPE SUNDIALS

Baluster Sundial Plinth D140

This simple baluster sundial design features cyma reversa moulding to both the square base and table. In each corner the table top has been decorated with vermiculated rustication (see below for details of X700 Brass Dial and Gnomon).

Width at top: 320mm (12½")
Width of base: 320mm (12½")

Height: 875mm (34½")
Weight: 51kg (112 lb)

Baluster Sundial Plinth D145 (Illustrated on page 51)

As Baluster Sundial D140 (see above) but without recess in the top, thereby allowing customers to use their own sundial plate or Crescent Sundial, see page 63.



Adam Sundial Plinth D135

(for Dial and Gnomon X710)

This octagonal sundial plinth is similar to the Adam Sundial Plinth D130 (see page 66); however, it features a larger table for use with the large X710 Brass Dial and Gnomon.

D135 table width: 520mm (20½")
Plinth base width: 430mm (17")
Height of plinth: 1070mm (42")
D135 plinth weight: 164kg (362 lb)



Georgian Sundial Plinth D260

A beautiful baluster sundial, after James Gibbs. See right for X700 Brass Dial and Gnomon. For Bird Bath, see page 68.

Table Diameter: 335mm (13¼")
Width of base: 335mm (13¼")
Height: 845mm (33¼")
Weight: 73kg (161 lb)

Georgian Sundial Plinth D265 (Illustrated on page 63)

As D260 but without recess on the top. Ideal for customer's own sundial or the Crescent Sundial, see page 63.



Brass Dials and Gnomons

Designed exclusively for use with the Haddonstone collection of sundials, both of these beautiful solid-brass dials and gnomons feature the Haddonstone sundial verse:

"Make time, save time while time lasts.
All time is no time when time is past."

Note: Plinths and dials are priced separately – see price list.

Brass Dial and Gnomon X700 (for D140, D150, D250 & D260 Plinths)

Diameter of dial: 290mm (11½")
Height of gnomon: 125mm (5")
Weight: 1.1kg (2½ lb)

Brass Dial and Gnomon X710 (for D280 & D135 Plinths)

Diameter of dial: 405mm (16")
Height of gnomon: 185mm (7¼")
Weight: 2.7kg (6 lb)



Arcadian Sundial GD350

A baluster-style sundial featuring a sun motif at the centre of the dial, surrounded by clouds, moon and stars. Includes gnomon.

Height: 575mm (22⁵/₈"")
 Max width: 375mm (14³/₄"")
 Total weight: 49kg (108 lb)
 Heaviest component: 35kg (77 lb)



Doric Sundial Plinth D150

This classical design with fluted shaft and moulded capital and base looks ideal on terraces or raised platforms (see left for details of X700 Brass Dial and Gnomon).

Diameter of table: 355mm (14")
 Width at base: 445mm (17¹/₂"")
 Height: 1080mm (42¹/₂"")
 Weight: 137kg (302 lb)



XVIII Century Sundial Plinth D250

A well-proportioned baluster sundial with artificial leaf design around the bowl and table (see left for details of X700 Brass Dial and Gnomon).

Diameter of table: 335mm (13¹/₄"")
 Width at base: 455mm (18")
 Height: 990mm (39")
 Weight: 112kg (248 lb)



Jacobean Sundial & Pedestal D280/B150

A circular sundial table supported by three putti and mounted on a pedestal enriched with fluting and ovolo ornament (see left for details of X710 Brass Dial and Gnomon). See also Figured Bird Bath (page 68) and Figured Fountain (page 96).

Diameter at top: 520mm (20¹/₂"")
 Width of base: 385mm (15¹/₄"")
 Height overall: 1340mm (52³/₄"")
 Weight overall: 195kg (429 lb)



Roman Sundial HD285

Featuring a stainless steel gnomon to project a shadow across the Roman numerals cast into the sundial top. See also Baluster Bird Bath (page 67) and Baluster Bird Table (page 67).

Diameter at top: 375mm (14³/₄"")
 Width of base: 260mm (10¹/₄"")
 Height: 670mm (26³/₈"")
 Weight: 43kg (95 lb)



Note: Plinths and dials are priced separately – see price list.

DAVIDHARBER

Armillary Sphere X714 (for B495 Pedestal/D130 Plinth)

Designed and created exclusively for Haddonstone by the world-renowned David Harber workshop, the Armillary Sphere is calibrated to tell solar time and features the Haddonstone sundial verse. Made from solid brass throughout, the Armillary Sphere has three rings depicting the equator, the meridian and a colure. The gnomon, casts a shadow onto the equator band which is engraved with Roman numerals. The sphere is supported by a cruxiform stand on a circular base for securing to the plinth. Fixing screws are supplied. The Sphere can be calibrated for any country in the world.

The Armillary Sphere features the Haddonstone sundial verse:

“Make time, save time while time lasts.
All time is no time when time is past.”

Diameter: 530mm (20⁷/₈”) Width of base: 190mm (7¹/₂”)
Height: 660mm (26”) Weight: 7kg (15¹/₂ lb)

Recommended pedestals: B495, D130



Adam Sundial Plinth D130 (for Armillary Sphere X714)

An octagonal sundial plinth, in the style of Robert Adam, decorated with masks and margents of husks. An elegant support for the Armillary Sphere sundial. See also, Adam Sundial Plinth page 64.

Width of table: 430mm (17”) Height of plinth: 1070mm (42”)
Width of plinth base: 430mm (17”) Weight of plinth: 152kg (335 lb)

(Registered Design No. 2013394)

Adam Pedestal B495 (for Armillary Sphere X714)

This stylish design - featuring a fluted shaft with palmette decoration to the base and capital - provides an alternative pedestal for the exclusive Armillary Sphere Sundial, see left.

Width at base: 358mm (14”) Height: 1087mm (42³/₄”)
Width at top: 345mm (13⁹/₁₆”) Weight: 123kg (271 lb)

(Registered Design No 2038747)



GARDEN & LANDSCAPE BIRD BATHS & BIRD TABLES



Arcadian Bird Table GC353

A recent addition to the range.

Height: 580mm (22⁷/₈"")
Maximum width: 420mm (16¹/₂"")
Weight: 50kg (110 lb)

Arcadian Bird Bath GC350

A stylish baluster bird bath.

Height: 610mm (24")
Max width: 560mm (22")
Total weight: 58kg (128lb)
Heaviest component: 35kg (77 lb)

Baluster Bird Table HC334

A new Haddonstone design.

Height: 710mm (28")
Maximum width: 560mm (22")
Weight: 68kg (150 lb)

Baluster Bird Bath HC335

A simple baluster bird bath.

Width at rim: 560mm (22")
Width at base: 260mm (10¹/₄"")
Height: 710mm (28")
Weight: 58kg (128 lb)

Regency Bird Bath HC500 Regency Pedestal HB330

A very popular small bird bath in the Regency style. See also Regency Fountain, page 96.

Width at top of bird bath: 510mm (20")
Width at base of bird bath: 220mm (8³/₄"")
Width at pedestal foot: 280mm (11")
Height (without pedestal): 340mm (13¹/₂"")
Height of pedestal: 430mm (17")
Weight of bird bath: 36kg (79 lb)
Weight of pedestal: 42kg (93 lb)

Figured Bird Bath C330

The pedestal for this charming bird bath is formed by three entwined putti who support the circular bird bath bowl with plain moulding and a fluted design to the rim. See also Jacobean Sundial (page 65) and Figured Fountain (page 96).

Width at top: 520mm (20½")
Width at base: 340mm (13½")
Height: 725mm (28½")
Weight: 75kg (165 lb)



Georgian Bird Bath HC340

This is a beautiful baluster-style bird bath, after James Gibbs. The strigillated baluster shaft is decorated with artificial leaf mouldings at the base. For Georgian Sundial, see pages 63-64.

Width at rim: 685mm (27")
Width at base: 335mm (13¼")
Height: 915mm (36")
Weight: 91kg (200 lb)

(Registered Design No.2013393)



Highland Park Bird Bath HC345

A stylish design to suit both contemporary and traditional gardens.

Width at top: 768mm (30¼")
Width at base: 368mm (14½")
Height: 870mm (34¼")
Weight: 85kg (187 lb)



Hazelwood Bird Bath HC280

An attractive Victorian design with shell decoration on the pedestal.

Width at rim: 585mm (23")
Width at base: 380mm (15")
Height: 850mm (34")
Weight: 76kg (167 lb)

GARDEN & LANDSCAPE STATUES

“There is nothing adds so much to the Beauty and Grandeur of Gardens, as fine Statues”

Batty Langley, 1728

Isis HE810

Acquired by Charles Townley, the famous collector, during his second Grand Tour of Italy (1771-74). Townley himself believed the bust represented Isis, considered by the ancients as the ideal mother and wife as well as patron of nature and magic.

Width of bust: 450mm (17³/₄"

Width of socle: 240mm (9¹/₂"

Height: 690mm (27¹/₄"

Weight: 65kg (143 lb)

Recommended pedestals: B170, B490, B495, B901



Apollo E700

Apollo was a great and powerful deity, one of the leading figures in all of mythology. Young and handsome, he became best known for his oracles and for his interest in music. A twin of Diana, or Artemis, Apollo is represented here in the classical style of Phidias, the 5th century BC Greek sculptor.

Height: 515mm (20¹/₄"

Max. base width: 235mm (9¹/₄"

Weight: 52kg (115 lb)

Recommended pedestals: B170, B490, B495



Diana E705

Diana, or Artemis, is the virgin huntress of classical mythology, sacred to all things natural and wild, protector of women in labour and newborn children. She was a proud and beautiful goddess and a formidable warrior. She assisted in the birth of Apollo, her twin brother, and the bond between them was very strong. Created here in the style of Phidias, the 5th century BC Greek sculptor.

Height: 530mm (20⁷/₈"

Max. base width: 295mm (11⁵/₈"

Weight: 48kg (106 lb)

Recom. pedestals: B170, B490, B495



Aurora HE800

Aurora, goddess of Dawn, after Michelangelo. The original forms an integral part of the Michelangelo's famous Tomb of Lorenzo di Piero de' Medici (1492-1519) in the Church of San Lorenzo, Florence. Machiavelli's 'The Prince' is dedicated to Lorenzo.

Width of bust: 285mm (11¹/₄"

Width of socle: 200mm (7⁷/₈"

Height: 550mm (21³/₄"

Weight: 24kg (53 lb)

Recommended pedestals: B130, B480, B490, B495

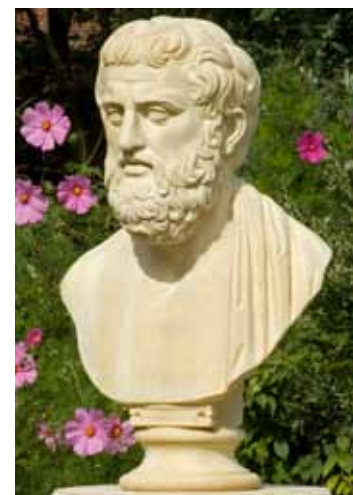

Aristotle HE805

One of the most important founding figures in Western philosophy, Aristotle (384-322 BC) was a student of Plato and teacher of Alexander the Great.

Width of bust: 350mm (13³/₄"

Width of socle: 175mm (6⁷/₈"

Height 567mm (22³/₈"

Weight: 29kg (64 lb)

Recommended pedestals: B130, B480, B490, B495

Turn to Specialist Services - Archives for further ornament options

TS Tech Sheet No. M56, M57 & M58 TS Tech Sheet No. GAR4 Security Fixings

Antinous HE840

Antinous (111-130 AD) was an important member of Emperor Hadrian's entourage. Deified by Hadrian after his death, Antinous came to be considered the personification of youthful beauty.

Width of bust: 550mm (21⁵/₈") Height: 790mm (31¹/₈")
 Width of socle: 250mm (9⁷/₈") Weight: 84kg (185 lb)
 Recommended pedestals: B170, B490, B495, B901



Eros HE845

This fine torso is a Roman copy of a Greek bronze original attributed to the sculptor Praxiteles. In Greek mythology Eros was the primordial god of sexual love and beauty. Inscribed "1378 TORSE ANTIQVE D'AMOVV. L'AMOVV GREC MUSE VATIC". The original marble is in the Vatican Museum.

Width: 440mm (17⁵/₈")
 Height: 970mm (38¹/₄")
 Weight: 103kg (227 lb)
 Recommended pedestals: B255, B265

Apollo Belvedere HE830

From the full size Roman marble copy, after the ancient Greek statue by Leochares embodying masculine beauty in all its plentitude, it is one of the most celebrated sculptures from classical antiquity. The original is in the Vatican Museum. Often paired with Diana Chasseresse.

Width of bust: 565mm (22¹/₄")
 Width of socle: 250mm (9⁷/₈")
 Height: 790mm (31¹/₈")
 Weight: 83kgs (183 lb)
 Recommended pedestals: B170, B490, B495, B901

Diane Chasseresse HE835

From the full size Roman marble copy, after the ancient Greek statue depicting Diana the Huntress by Leochares. Prominently displayed at Fontainebleau in the sixteenth century, the original marble is now in the Louvre, Paris. Often paired with Apollo Belvedere.

Width of bust: 420mm (16¹/₂")
 Width of socle: 220mm (8⁵/₈")
 Height 740mm (29¹/₂")
 Weight: 50kg (110 lb)
 Recommended pedestals: B170, B490, B495, B901



GARDEN & LANDSCAPE STATUES

Caesar Augustus HE815

Caesar Augustus (63BC – 14AD), was the first Emperor of the Roman Empire, ruling alone from 31 BC. This bust is replicated from a marble statue excavated in 1863 at Prima Porta near Rome and now displayed at the Vatican Museum. Caesar Augustus, whose great uncle was Julius Caesar, is depicted in armour as commander-in-chief of the Roman army.

Width of bust: 500mm (19³/₄"

Width of socle: 230mm (9¹/₈"

Height: 740mm (29¹/₂"

Weight: 67kg (148 lb)

Recommended pedestals: B170, B490, B495, B901



Antoninus Pius HE820

Antoninus Pius, Roman Emperor from 138-161 AD, was the adoptive son and successor to Hadrian. He instigated the construction of the Antonine Wall between the Firths of Clyde and Forth.

Width of bust: 640mm (25¹/₄"

Height: 860mm (33⁷/₈"

Width of socle: 220mm (8⁵/₈"

Weight: 92kg (203 lb)

Recommended pedestals: B170, B490, B495, B901



Septimius Severus HE825

Septimius Severus (145-211 AD) was Roman Emperor from 193 AD. Severus was considered a strong, able ruler who sought glory through military exploits.

Width of bust: 520mm (20¹/₂"

Height: 840mm (33¹/₈"

Width of socle: 230mm (9¹/₄"

Weight: 80kg (176 lb)

Recommended pedestals: B170, B490, B495, B901

Brutus E195

Taken from an original carved by Michelangelo, which now stands in the Bargello Museum, Florence, this bust conveys the power of Brutus to an extraordinary degree of grandeur.

Width of bust overall: 750mm (29½")

Width of socle: 320mm (12½")

Height: 970mm (38¼")

Weight: 142kg (313 lb)

Recommended pedestals: B140, B265



Bacchus E190

A bust of the god of wine wearing an animal skin and cloak, usually mounted on our Doric Pedestal (see page 62).

Width of bust: 690mm (27")

Width of socle: 290mm (11½")

Height of bust: 965mm (38")

Weight: 96kg (211 lb)

Recommended pedestals: B100, B170, B265

Bacchante E180

Originating in Italy, circa 1870, this bust depicts a Bacchante, a reveller in the court of Bacchus, god of wine. Featuring vine-entwined hair and a loosely draped robe, she is designed for display on our Doric Pedestal (see page 62).

Width of bust: 560mm (22")

Width of socle: 290mm (11½")

Height: 880mm (34⅝")

Weight: 100kg (220 lb)

Recommended pedestals: B100, B170, B265





Pan Term E690

This magnificent term depicts Pan, the Arcadian god of hills and woods, who is the protecting deity of flocks and herdsmen. He is portrayed as having the body of a man, but with the beard and horns of a goat, playing his syrinx. A beautiful lion's skin, complete with mask, robes his body and drapes the term pedestal shaft. Traditionally used for terminating a path or hedge, or alternatively is ideal for positioning in a temple or grotto or as a focal point in a garden scheme.

Height: 2020mm (79½")
 Width at base: 700mm (27½")
 Weight: 426kg (939 lb)

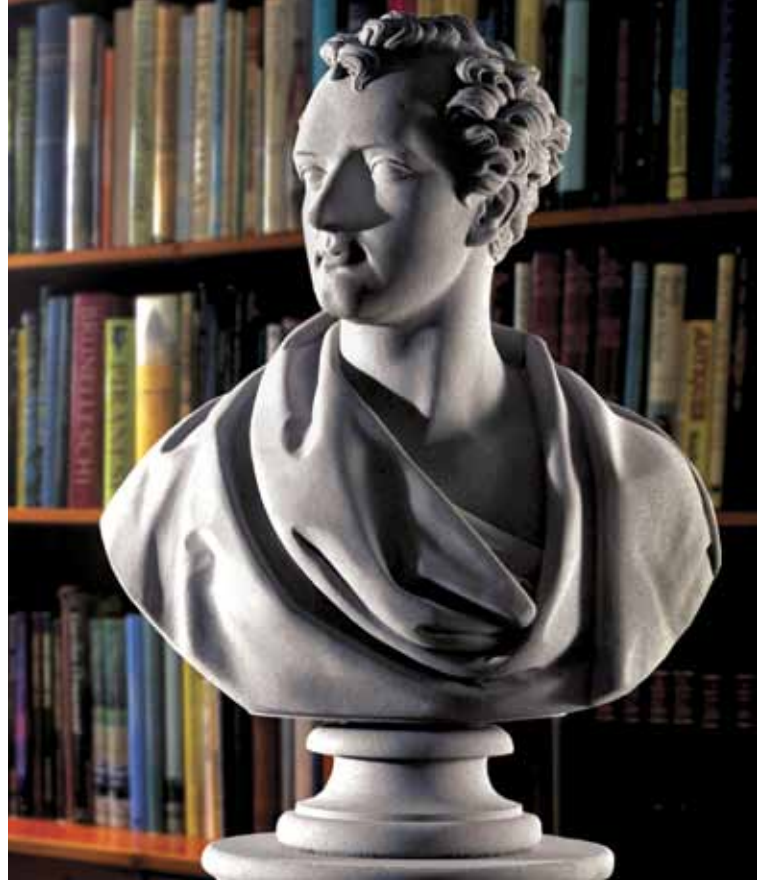

Byron E175

Lord Byron was famously described as being "mad, bad and dangerous to know" by Lady Caroline Lamb. Byron (1788-1824) was an icon of his age and the subject of a major exhibition at the National Portrait Gallery in London during 2003.

Haddonstone's Byron is taken from a fine marble original carved by Edward Hodges Baily RA in c1826. During his lifetime, Byron was much admired for his extraordinary beauty of appearance as well as his poetic genius. Haddonstone's replica captures the very essence of Byron.

Width of bust: 520mm (20½")
 Width of socle: 214mm (8½")
 Height: 790mm (31")
 Weight: 71kg (156 lb)

Recommended pedestals:
 B490, B495



Bust of Pan E695

This bust is taken from our Pan Term E690.

Height: 770mm (30¼")
 Width overall: 540mm (21¼")
 Width at base: 250mm (9⅞")
 Weight: 85kg (187 lb)

Recommended pedestal: B310,
 B440, B490, B495.

Helena E170

This beautiful bust, from an original by the renowned XIX century sculptor Charles Francis Fuller, depicts a young Roman maiden whom we have called Helena. Shown here on an Adam Pedestal (see page 62).

Height: 695mm (27³/₈"

Width overall: 457mm (18")

Width of base: 250mm (9⁷/₈"

Weight: 55kg (121 lb)

Recommended pedestals: B310,
B440, B490, B495.



GARDEN & LANDSCAPE STATUES

THE FOUR ELEMENTS

HADDONSTONE WAS COMMISSIONED BY STOCKPORT BOROUGH COUNCIL TO REPRODUCE THIS CHARMING GROUP OF ELEMENTS FOR THE DUTCH GARDEN AT LYME HALL, CHESHIRE. THE ORIGINALS WERE CARVED IN THE EARLY 1800S FOR ELVEDEN HALL, NORFOLK.



Earth HE600

Height: 1010mm (39¾")
Max. base width: 455mm (18")
Weight: 113kg (249 lb)



Fire HE610

Height: 1010mm (39¾")
Max. base width: 405mm (16")
Weight: 121kg (266 lb)



Air HE620

Height: 980mm (38½")
Max. base width: 395mm (15½")
Weight: 102kg (225 lb)



Water HE630

Height: 995mm (39¼")
Max. base width: 410mm (16¼")
Weight: 119kg (262 lb)

Recommended pedestals: B255,
B265, B370

THE FOUR SEASONS

THIS SERIES OF STATUES DEPICTING THE SEASONS WAS SPECIALLY COMMISSIONED BY HADDONSTONE.

Spring stands demurely holding a sprig of pussy willow in her right hand, Summer stands gracefully holding a sheaf of corn in her hand, Autumn is depicted holding freshly harvested grapes within her skirts, whilst Winter stands with oak entwined hair and her left arm warmly wrapped with drapery. See also Water Nymph page 91.

Height: 1430mm (56¼")
Max. base width: 360mm (14¼")
Weight: 140kg (308 lb)

Recommended pedestals: B255, B265, B370



Spring HE750

(Registered Design No 2086381)



Autumn HE760

(Registered Design No 2092420)



Winter HE765

(Registered Design No 2092835)

Summer HE755

(Registered Design No 2091580)

GARDEN & LANDSCAPE STATUES



Piper HE660

This charming figure of a young boy playing a pipe has been modelled by Haddonstone from an antique copy of the original that stood in the Villa Borghese until purchased by Napoleon Bonaparte and subsequently displayed in the Louvre. Shown on Dado Pedestal (see page 60).

Height: 1380mm (54 1/4")
Max. base width: 355mm (14")
Weight: 140kg (308 lb)

Recommended pedestals: B255, B265, B370



Shepherdess HE655

The Shepherdess statue has been created to provide the Gardener design with a partner. She is depicted in the style of a rustic, in period dress with bonnet, laced bodice, flowing skirt and buckle shoes. In her right hand she holds a wrought iron crook and under her left arm she gently cradles a small lamb.

Height: 1380mm (54 1/4")
Max base width: 350mm (13 3/4")
Weight: 132kg (291 lb)

Recommended pedestals: B255, B265, B370



Andromeda E640

Taken from a XIX century Italian original, Andromeda stands, scantily clad, clutching a robe to her right breast whilst manacled to a rocky outcrop. In classical mythology Andromeda was chained to a rock before being found by the hero Perseus who released her, slew a monster and obtained her as his wife.

Height: 1030mm (40 3/4")
Max. base width: 345mm (13 1/2")
Weight: 80kg (176 lb)

Recommended pedestals: B255, B340, B350



Venus E680

Venus, the goddess of love and fertility, is replicated from a late XIX century Italian white-marble sculpture. She is depicted with flowing locks, resting against a rocky promontory, a robe loosely draped around her body.

Height: 840mm (33")
Max. base width: 280mm (11")
Weight: 57kg (126 lb)

Recommended pedestals: B335, B400



The Gardener HE650

Inspired by the engaging lead figure that once stood at Burton Agnes in Yorkshire, Haddonstone created this statue of an XVIII century gardener, in period dress, resting on his spade.

Height: 1380mm (54 1/4")

Max. base width: 355mm (14")

Weight: 140kg (308 lb)

Recommended pedestals: B255, B265, B370

(Registered Design No. 2083190)



Music HE670

Music holds a classical lyre in her left hand, an instrument attributed to the Greek God Hermes. Originally created for the restoration of Leazes Park in Newcastle, this design is identical in proportion to Poetry.

Height: 1800mm (71")

Width at base: 650mm (25 5/8")

Weight: 465kg (1 024 lb)

Please note: will require mechanical lifting on site in all instances.



Poetry HE671

This elegant statue, representing Poetry, stands clutching a bound volume of verse. Originally created for the restoration of Leazes Park in Newcastle, this design is identical in proportion to Music.

Height: 1800mm (71")

Width at base: 650mm (25 5/8")

Weight: 395kg (870 lb)

Please note: will require mechanical lifting on site in all instances.

GARDEN & LANDSCAPE STATUES

Equine Head E570

The original of this impressive Equine Head was excavated at Civitavecchia near Rome and acquired by the Medici family who sent it to Florence in 1585. It was later adapted to serve as a fountain spout in the courtyard of the Medici Palace.

Depth of bust: 890mm (35")
 Width of bust base: 340mm (13½")
 Width of socle: 380mm (15")
 Height: 1010mm (39¾")
 Weight: 183kg (403 lb)

Recommended pedestals: B120, B265



Large Lion Finial HE461

This massive lion was originally created for a project in Qatar. Identical in proportion to the Lion Finial E460.

Base width: 780mm (30¾")
 Height: 2040mm (80⅝")
 Weight: 1500kg (3304 lb)

Please note: will require mechanical lifting on site in all instances.

Lion Finial E460 Lion Base A370B

This lion sejant may also be used as a fountain (see page 91). Shown mounted on a waisted octagonal base.

Width at lion base: 280mm (11")
 Width of base: 355mm (14")
 Height of lion: 610mm (24")
 Height of base: 280mm (11")
 Weight of lion: 35kg (77 lb)
 Weight of base: 35kg (77 lb)

XVIII Century Lion E450 XVIII Century Lion Pedestal B200

Well-proportioned lion couchant, which can be mounted on the B200 pedestal. Suitable for terraces or tops of steps. See Specialist Services - Archives for Large XVIII Century Lion.

Length of lion: 610mm (24")
 Width of lion: 280mm (11")
 Height of lion: 405mm (16")
 Weight of lion: 56kg (125 lb)
 Length of pedestal at foot: 645mm (25½")
 Width of pedestal at foot: 330mm (13")
 Height of pedestal: 240mm (9½")
 Weight of pedestal: 57kg (126 lb)

Aquila (left hand) HE357
Aquila (right hand) HE358

Aquila was the immortal eagle of Zeus, king of the gods. Since ancient times, the eagle has been considered a symbol of power and victory. This pair of eagles was originally created as part of the restoration of Leazes Park in Newcastle.

Height overall: 825mm (32 1/2")
 Width overall: 750mm (29 1/2")
 Diameter of base: 410mm (16 1/8")
 Weight (each): 130kg (286 lb)



Eagle Owl E565

Eagle Owls are among the largest and most magnificent of the owls - noted for their large size, conspicuous ear tufts, eagle-like bills and enormously powerful talons. This Haddonstone design captures the power of this bird of prey.

Height: 720mm (28 3/8")
 Width at base: 317mm (12 1/2")
 Weight: 56kg (123 lb)

Recommended pedestals: B150, B331, B400, B420, B440, B695

(Registered Design No. 2084729)



Eagle (left hand) HE350 Eagle (right hand) HE355

These powerful representations of the noble eagle are ideal for positioning on a gateway, at the entrance to a garden walk, or to frame a landscape vista. Adapted from original designs by Doulton of Lambeth.

Height overall: 930mm (36 5/8")
 Width overall: 800mm (31 1/2")
 Width at base: 370mm (14 1/2")

Depth overall: 580mm (22 3/4")
 Depth at base: 370mm (14 1/2")
 Weight (each): 174kg (383 lb)

Recommended pedestal: B120

GARDEN & LANDSCAPE GARDEN PET MEMORIALS

Haddonstone has introduced a unique range of Garden Pet Memorials. Exceptionally crafted, yet unobtrusive, these provide both a beautiful ornament and a discreet receptacle for a cherished pet's remains.

Each design (not the Memorial Block, Memorial Marker or Memorial Stone) incorporates a pedestal which can accommodate one or two Poly-Urns for your pet's ashes (one supplied with memorial). To personalize these memorials an inscription panel is recess fixed into the pedestal. Garden Pet Memorials are designed to be used as a garden ornament and may be placed in a pet's favourite area of the garden. Memorials can easily be relocated at a future time if required.

In addition to Garden Pet Memorials, Haddonstone engraves some standard ornaments, see page 196. Garden Cremation Memorials also available, see page 194.



Memorial Stone MEM850

(Shown with standard engraved inscription with optional enamel lettering infill)

Height: 450mm (17³/₄"

Height above ground: approx 305mm (12")

Width: 210mm (8¹/₄"

Weight: 7kg (15 lb)



Memorial Vase & Pedestal MEM300

(Standard engraved inscription shown)

Width at top: 510mm (20")

Pedestal base width: 338mm (13¹/₄"

Height: 980mm (38⁵/₈"

Weight: 88kg (194 lb)



Small Bird (optional) MEM800



Memorial Celestial Sundial & Pedestal

MEM200 (detail below left)

Memorial Classical Sundial & Pedestal

MEM100 (detail below right)

Sundial diameter: 375mm (14³/₄"

Pedestal base width: 338mm (13¹/₄"

Stone height: 880mm (34⁵/₈"

Weight: 81kg (178 lb)



Celestial (detail)

Classical (detail)



Memorial Fountain & Pedestal MEM500

Fountain diameter: 305mm (12")

Pedestal base width: 338mm (13¹/₄"

Height: 890mm (35")

Weight: 88kg (194 lb)

Memorial Marker MEM840 (right)

(Shown with standard engraved inscription with optional enamel lettering infill)

Dimensions: 300 x 300 x 38mm
(11¹³/₁₆ x 11¹³/₁₆ x 1¹/₂"

Weight: 7kg (15 lb)

Other sizes available on request.



Memorial Bird Bath & Pedestal MEM400

Width at top: 485mm (19")

Pedestal base width: 338mm (13¹/₄"

Height: 927mm (36¹/₂"

Weight: 96kg (211 lb)



GARDEN & LANDSCAPE FINIALS

Finials are normally used to adorn gate piers, entrances or balustrading. They provide a decorative alternative to the geometric Ball & Base designs (see page 86). Many of Haddonstone's finials have been replicated from notable country houses including National Trust properties. Alongside these standard designs, Haddonstone is also able to create custom designs to meet individual requirements or to replicate an existing design as part of a restoration project.



Ven Finial
E715

Replicated as part of the restoration of the William-and-Mary-style country house of Ven in Dorset, this exquisite finial is now included in the Haddonstone Collection.

Height: 826mm (32½")
Width overall: 390mm (15¼")
Width at base: 245mm (9¾")
Weight: 43kg (95 lb)



Vine House Finial
E730

Sir Christopher Wren has been authoritatively associated with the original finial from which this Haddonstone design has been developed.

Height: 790mm (31")
Width overall: 410mm (16")
Width at base: 230mm (9")
Weight: 45kg (100 lb)



Swagged Adam Finial
E740

An Adam-style finial with a scalloped lid surmounted by a naturalistic bud. The main decoration to the finial comprises drapery swags terminated with disc moulding and lion masks over a fluted body. The lid may be removed, allowing this finial to be planted during the spring and summer months. See also Swagged Adam Vase, page 32.

Height: 762mm (30")
Width overall: 495mm (19½")
Width at base: 229mm (9")
Weight: 64kg (141 lb)

(Registered Design No. 2039118)

GARDEN & LANDSCAPE FINIALS

Margam Swagged Urn E510

A very elegant Georgian urn with formal floral and lion-head decoration. Haddonstone was commissioned to restore the original urns at Margam Orangery, South Wales, as part of the British project for the 1975 European Architectural Heritage Year. Originally manufactured by the illustrious Coade company.

Width overall: 585mm (23")
 Width at base: 255mm (10")
 Height: 660mm (26")
 Weight: 75kg (165 lb)



Ham House Pineapple E380

The National Trust granted the right for Haddonstone to include in its Collection a perfect replica of the beautiful Coade Stone pineapples adorning the perimeter pedestals at Ham House, Richmond.

Height: 820mm (32¼")
 Width overall: 455mm (18")
 Width at base: 300mm (11¾")
 Weight: 95kg (209 lb)



Pineapple and Base E590

An early XVIII century pineapple design.

Height: 585mm (23")
 Width overall: 345mm (13½")
 Width at base: 280mm (11")
 Weight: 43kg (95 lb)



Margam Masked Urn E500

A Georgian-style urn adorned in high relief with naturalistic vines and satyr heads. This piece was also restored for Margam Orangery, South Wales.

Width overall: 560mm (22")
 Width at base: 255mm (10")
 Height: 915mm (36")
 Weight: 78kg (172 lb)



Rugby Finial E595

Replicated from an original design on behalf of Rugby Borough Council, this finial features strong gadrooning to the body with moulded top surmounted by a flame.

Height: 1300mm (51¼")
 Width overall: 450mm (17¾")
 Width at base: 290mm (11½")
 Weight: 107kg (236 lb)

Large Basket of Fruit

E220

This neo-Gothic-style basket with interlaced strapwork overflows with ripe fruits in a naturalistic style.

Height: 455mm (18")

Width overall: 470mm (18½")

Width at base: 230mm (9")

Weight: 45kg (98 lb)



Lyme Hall Urn

E480

This splendid ram's-head finial was originally commissioned for Lyme Hall by Stockport Borough Council. It can be mounted on a pedestal at low level or at parapet level to dramatic effect.

Width overall: 660mm (26")

Width at base: 290mm (11½")

Height: 1145mm (45")

Weight: 115kg (254 lb)

Dogmersfield Finial

E280

A replica of a finial designed for Dogmersfield Park, Hampshire, in 1742.

Height: 1500mm (59")

Width overall: 650mm (25½")

Width at base: 385mm (15")

Weight: 158kg (348 lb)



Festoon of Fruit

E230

The Festoon of Fruit comprises a fluted vase, gadrooned stem and waved top line with a beautifully detailed cornucopia of fruit

Height: 600mm (23½")

Width overall: 390mm (15½")

Width at base: 230mm (9")

Weight: 48kg (106 lb)



Basket of Fruit

E200

This small basket with relief basketweave pattern contains ornate and rotund fruits, and is ideal as a table centrepiece.

Height: 310mm (12¼")

Width overall: 310mm (12¼")

Width at base: 190mm (7½")

Weight: 21kg (46 lb)

GARDEN & LANDSCAPE BALLS AND BASES

6¾" Ball E100A & Base E100B

Height: 265mm (10½")
 Diameter of ball: 170mm (6¾")
 Width at base: 230mm (9")
 Weight: 10kg (22 lb)



Acanthus-Leaf Ball E080A & Collared Base E120C

Height: 620mm (24½")
 Max diameter: 400mm (15¾")
 Width at base: 330mm (13")
 Weight: 63kg (139 lb)

8" Ball E105A & Base E100B

Height: 295mm (11¾")
 Diameter of ball: 200mm (8")
 Width at base: 230mm (9")
 Weight: 12kg (27 lb)

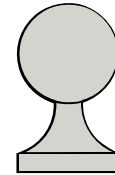

14" Ball E130A & Base E120B

Height: 595mm (23½")
 Diameter of ball: 355mm (14")
 Width at base: 330mm (13")
 Weight: 64kg (141 lb)

9" Ball E110A & Collared Base E110C

Height: 455mm (18")
 Diameter of ball: 230mm (9")
 Width at base: 230mm (9")
 Weight: 23kg (51 lb)

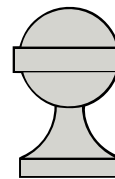

Vanbrugh Ball E710A & Base E120B

Height: 560mm (22")
 Width: 370mm (14½")
 Width at base: 330mm (13")
 Weight: 59kg (130 lb)



13" Ball E120A & Collared Base E120C on Pier Cap S940C



Acanthus-leaf Ball E080A & Collared Base E120C on Pier Block S140B and Pier Cap S940C



Vanbrugh Ball E710A & Base E120B on Pier Cap S940C

11" Ball E115A & Base E120B

Height: 520mm (20½")
 Diameter of ball: 280mm (11")
 Width at base: 330mm (13")
 Weight: 42kg (93 lb)

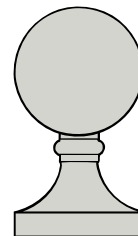
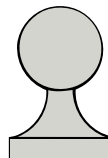

17" Ball E140A & Collared Base E140C

This ball and base is of similar design to the E120 13" Ball and Collared Base. Ball supplied with lifting socket.
 Height: 775mm (30½")
 Diameter of ball: 430mm (17")
 Width at base: 430mm (17")
 Weight: 119kg (262 lb)

13" Ball E120A & Collared Base E120C

Height: 620mm (24½")
 Diameter of ball: 330mm (13")
 Width at base: 330mm (13")
 Weight: 58kg (128 lb)

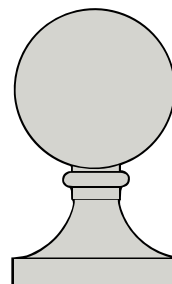
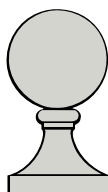

21" Ball E150A & Collared Base E150C

Ball supplied with lifting socket.
 Height: 945mm (37¼")
 Diameter of ball: 535mm (21")
 Width at base: 560mm (22")
 Weight of ball: 143kg (315 lb)
 Weight of base: 82kg (181 lb)

GARDEN & LANDSCAPE GARDEN FURNITURE

Circular Table

This table features a circular top with a simple decorated centre panel and moulded edging. This can be mounted on four D460 Lion Supports.

Circular Table Top D450

Diameter: 1370mm (54")

Thickness: 80mm (3 1/8")

Weight: 186kg (410 lb)

Lion Support D460

Width at base: 290mm (11 1/2")

Height: 710mm (28")

Weight: 45kg (99 lb) each



GARDEN & LANDSCAPE GARDEN FURNITURE

Scrolled Bench Seats

Bench seats with vine and scrollwork supports, available in straight and curved form. The standard curved and straight sections can be arranged in various combinations to suit individual requirements; the standard combinations are shown in the Seat Data table below.

Width of seat top: 405mm (15¹⁵/₁₆"")
 Overall height of seat: 457mm (18")
 Lengths and weights: (see table)

TS Tech Sheet No. M75 & M76

IMPORTANT

INSTALLATION DETAILS

It is essential that your Haddonstone seat or table is sited on a firm and level area. Although the top is reinforced, it may crack if subjected to a pivoting or twisting strain. An 8 to 1 sand/cement bedding mortar must be used to ensure that each support bears an equal weight. The properties of this mixture give a secure hold that can be broken without difficulty if the seat has to be re-sited. We cannot accept responsibility for breakage if this instruction is ignored.



HD311 Straight 51" Bench Seat including 2 Scrolled Seat Supports



HD332 Double Curved 54" Bench Seat including 5 Scrolled Seat Supports

SCROLLED BENCH SEAT DATA							
TYPE	CODE	SUPPORTS REQUIRED (D400A)	LENGTH/ OUTER GIRTH (excluding joints)	OUTER CHORD	RADIUS		OVERALL WEIGHT (Supports 25kg each)
					INNER	OUTER	
Single 51 Straight	HD311	2	1295mm (51")	N/A	N/A	N/A	135kg (297 lb)
Single 52 Curved	HD321	3	1380mm (54 1/4")	1320mm (52")	920mm (36 1/4")	1325mm (52 1/4")	156kg (344 lb)
Single 54 Curved	HD331	3	1400mm (55")	1365mm (54")	1385mm (54 1/2")	1790mm (70 1/2")	160kg (352 lb)
Double 54 Curved	HD332	5	2800mm (110 1/4")	N/A	1385mm (54 1/2")	1790mm (70 1/2")	295kg (650 lb)
Single 60 Curved	HD341	3	1540mm (60 1/2")	1525mm (60")	3100mm (122")	3505mm (138")	171kg (377 lb)

Note Type number on curved seats indicates approx. outer chord length in inches



HD321 Curved 52" Bench Seat including 3 Scrolled Seat Supports



HD431 Curved 47" Egg and Dart Bench Seat including 3 Chimera Seat Supports



HD421 Straight 51" Egg and Dart Bench Seat including 2 Chimera Seat Supports

Egg and Dart Seat Tops

A range of ornate bench seat tops decorated with an egg and dart design with a leaf motif to each corner. Designed specifically for use with the D405 Chimera Seat Support, they may also be used with the D400 Support.

(Registered Design No. 2042756)

TS Tech Sheet No. M77

Chimera Seat Support D405

Exquisite design in the form of a Chimera, a mythological beast popular in the XVIII century. May be used with standard seat tops.

Length (base): 383mm (15")

Width (base): 135mm (5 1/4")

Height: 393mm (15 1/2")

Weight: 25kg (55 lb)

(Registered Design No. 2042755)



Hadrian Seat HD520

Responding to requests from numerous clients, Haddonstone has created an elegant bench seat of modest proportions incorporating a panelled back, scrolled arm rests, chimera supports and an egg and dart seat top. Rebates are provided for fixings (not supplied), required if used in a public area only. Engraving possible, see page 196. HD525 version also available, featuring scrolled support based on D400A design, see page 88.

Length: 1335mm (52 1/2")

Height: 850mm (33 1/2")

Depth: 495mm (19 1/2")

Weight: 269kg (593 lb)

EGG AND DART SEAT DATA

TYPE	CODE	SUPPORTS (D405A)	LENGTH/OUTER GIRTH	OUTER CHORD	RADIUS		OVERALL WEIGHT (Support 25kg ea.)
					INNER	OUTER	
Straight 51	HD421	2	1295mm (51")	N/A	N/A	N/A	140kg (308 lb)
Curved 47	HD431	3	1240mm (48 7/8")	1190mm (46 7/8")	845mm (33 3/8")	1250mm (49 1/4")	163kg (359 lb)



Original concept for Ram Supports: Lingard + Styles, landscape architects

Raphael Seat D510 (including Ram Supports)

Designed for a livery company in the City of London. Using four rams couchant, this is an interesting variation on the original Raphael Seat. For dimensions see Raphael Seat D500 below.

(Registered Design No.2006991)

TS Tech Sheet No. M70 & M71

Raphael Seat D500

The imposing Raphael Seat incorporates decorative panels thought to be inspired by Raphael's grotesque decorations in the Vatican with both Etruscan and early English Renaissance influences.

Length: 2217mm (87 ½")

Depth: 609mm (24")

Height: 1194mm (47")

Weight: 875kg (1930 lb)

(Registered Design No. 2006991)

TS Tech Sheet No. M70 & M71



GARDEN & LANDSCAPE FOUNTAINS - CENTREPIECE

General Note: Simple precautions should be taken to avoid frost damage to fountains. Water should be drained off before winter every year and not replaced until spring when any risk of hard frost has passed.

Single Dolphin Fountain HC171

Height: 740mm (29 1/8")
Weight: 25kg (55 lb)

Recommended Pump: X210



Large Dolphin Fountain C172

The dolphin is considered the king of the fish. In classical ornament the dolphin often appears as an attribute of Neptune, the Roman god of the sea. This piece was inspired by early XVI century Italianate designs. For pedestal see S310S string on page 148.

Height: 905mm (35 1/2")
Length overall: 700mm (27 1/2")
Width overall: 670mm (26 1/2")
Weight: 94kg (207 lb)

Recommended pump: X220



Lion Fountain C300 Fountain Base C305

The lion sejant shown as a fountain with water spouting from its mouth. It is mounted on a waisted octagonal base. Also available as a finial, see page 80.

Width at lion base: 280mm (11")
Width at base: 355mm (14")
Height of lion: 610mm (24")
Height of base: 280mm (11")
Weight of lion: 36kg (79 lb)
Weight of base: 31kg (68 lb)

Recommended pump: X210

Water Nymph HC390

This charming design features a water nymph in a classical pose. The fountain can be positioned either adjacent to a pool or used as a centrepiece. Can be supported on an A240 Plinth, see page 44. A complementary design to Haddonstone's Seasons statues (see page 77).

Height: 1005mm (39 1/2")
Base diameter: 435mm (17 1/8")
Weight: 135kg (297 lb)

Recommended Pump: X210



West Lodge Fountain HC780

Replicated for the West Lodge Park Hotel in Hertfordshire, this elegant fountain is ideal for use as a centrepiece in a small pool. One of the latest additions to the Haddonstone Collection. For Urn see page 27.

Height: 527mm (20 3/4")
Width overall: 660mm (26")
Width at base: 273mm (10 3/4")
Weight: 74kg (163 lb)

Recommended pump: X210

GARDEN & LANDSCAPE FOUNTAINS - CENTREPIECE

Neapolitan Fountain C3700

A centrepiece fountain featuring a Boy-holding-dolphin centrepiece, the dolphin's mouth being the fountain head. Supported by an ornate base, the fountain bowl is the shape of a round shell.

Width of shell: 955mm (37⁵/₈"")
 Height of shell: 255mm (10")
 Width of base: 495mm (19¹/₂"")
 Overall height: 1395mm (55")
 Weight: 210kg (463 lb)

Recommended pump: X220

TS Tech Sheet No. F30



Boy-holding-dolphin Centrepiece C370A

Height: 510mm (20")
 Width at base: 180mm (7")
 Weight: 15kg (33 lb)

Recommended pump: X201

General Note: Simple precautions should be taken to avoid frost damage to fountains. Water should be drained off before winter every year and not replaced until spring when any risk of hard frost has passed.



Small Neapolitan Fountain C3750

This charming small fountain features an ornate shell bowl with a naturalistic bud fountain head. Ideal for use as a centrepiece in a small pool.

Width of shell: 460mm (18")
 Width of base: 250mm (9⁷/₈"")
 Overall height: 655mm (25³/₄"")
 Weight: 36kg (79 lb)

Recommended pump: X201
 Optional Pump Housing: HC360I

TS Tech Sheet No. F53



Neapolitan Small Double Fountain C3650

Formed by two ornate shell bowls and pedestals with a naturalistic bud fountain head, this fountain is ideal as a centrepiece for the Small Pool.

Upper shell width: 460mm (18")
 Lower shell width: 680mm (26³/₄"")
 Width of base: 325mm (12³/₄"")
 Overall height: 1175mm (46¹/₄"")
 Weight: 99kg (218 lb)

Recommended pump: X210
 Optional Pump Housing: HC360H

TS Tech Sheet No. F52



Neapolitan Large Double Fountain C3550

A large double fountain with ornate shell bowls and pedestals supporting an entwined triple-dolphin centrepiece. Suitable for a Medium Pool.

Upper shell width: 680mm (26³/₄"")
 Lower shell width: 955mm (37⁵/₈"")
 Base width: 495mm (19¹/₂"")
 Overall height: 1705mm (67¹/₈"")
 Weight: 262kg (578 lb)

(Registered Design No. 2030926)

Recommended pump: X230

TS Tech Sheet No. F51



Eton College Fountain C3600

The original for this exquisite triple fountain stood in the Cloister Court of Eton College, Windsor. The badly eroded original has now been replaced by a Haddonstone replica to restore this feature to its former glory.

The fountain comprises ornate pedestals supporting three decorative shell bowls surmounted by a naturalistic bud.

Upper shell width: 460mm (18")
Middle shell width: 680mm (26¾")
Lower shell width: 955mm (37⅝")
Base width: 495mm (19½")
Overall height: 1860mm (73¼")
Weight: 269kg (593 lb)

Recommended pump: X230

TS Tech Sheet No. F50

GARDEN & LANDSCAPE FOUNTAINS - CENTREPIECE

Triple Lotus Bowl Fountain HC3500

Launched at the 1997 Chelsea Flower Show, each bowl of this powerful triple-tiered fountain is supported by fluted pedestals featuring stylised Ionic capitals with the top bowl surmounted by a naturalistic bud. This original design by Haddonstone is based around the standard Lotus Bowl. Ideal for use as a centrepiece to Haddonstone's L, XL and XXL pool surrounds, see page 99.

Upper bowl diameter: 800mm (31½") Width of base: 500mm (19¾")
Middle bowl diameter: 1200mm (47¼") Overall Height: 2777mm (109⅝")
Lower bowl diameter: 1830mm (72") Weight: 1300kg (2863 lb)

(Registered Design No. 2059936) Recommended pump: X240

Please note: Lower bowl will require mechanical lifting on site in all instances.

TS Tech Sheet No. F70 & F71



Lotus Bowl HC350 on Pedestal HD2900 or HD2901

The Lotus Bowl makes a spectacular fountain. It may be combined with three dolphins as its centrepiece and mounted on a Doric pedestal (HD2900 or HD2901). (For Triple Dolphin Fountain C1700 and Pedestal C180, see page 96.)

HC350 Weight: 690kg (1520 lb)
HD2900 Height: 1084mm (42¾")
HD2900 Weight: 181kg (399 lb)
HD2901 Height: 1190mm (46⅞")
HD2901 Weight: 194kg (427 lb)

TS Tech Sheet No. F20 & F21

Please note: will require mechanical lifting on site in all instances.

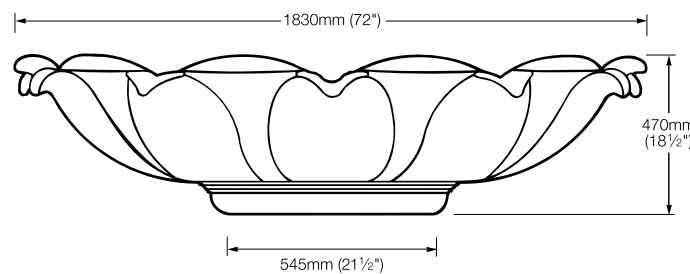

Double Lotus Fountain HC3510

Incorporating the top tiers of the Triple Lotus Fountain, this design was launched at the 1998 Chelsea Flower Show.

Diameter of upper bowl: 800mm (31½")
Diameter of lower bowl: 1200mm (47¼")
Width of base: 334mm (13⅜")
Overall height: 1692mm (66⅝")
Weight: 367kg (808 lb)

Recommended pump: X230

TS Tech Sheet No. F72

Quadruple Lotus Bowl Fountain HC358

This imposing four-tiered fountain is supported by fluted pedestals featuring stylised Ionic capitals to the three upper bowls with the top bowl surmounted by a naturalistic bud. This original design by Haddonstone is based around the standard Triple Lotus Fountain. Shown in XXL Pool Surround. Bottom shell supplied in three segments.

Upper bowl diameter: 800mm (31½")
Second bowl diameter: 1200mm (47¼")
Third bowl diameter: 1830mm (72")
Bottom bowl diameter: 3660mm (144")
Width of base: 850mm (33½")
Overall height: 4470mm (176")
Weight: 6588kg (14511 lb)

Pump to be supplied by others. Please note: will require mechanical lifting in all instances.



GARDEN & LANDSCAPE FOUNTAINS - CENTREPIECE

Fontainebleau Fountain C230

For details see Fontainebleau Urn A300 on page 33. Shown on a B360 Large Winslow Pedestal, see page 60. An inverted S310S string may also be used - see page 148.

Recommended pump: X220

TS Tech Sheet No. F80

General Note: Simple precautions should be taken to avoid frost damage to fountains. Water should be drained off before winter every year and not replaced until spring when any risk of hard frost has passed.



Regency Fountain HC510

Shown with non-standard jet. Supplied with Brass Rose Jet X270, see Romanesque Fountain, page 104.

Width at rim: 510mm (20")
Width at base: 220mm (8¾")
Height: 340mm (13½")
Weight: 36kg (79 lb)
Recommended pump: X210

Regency Pedestal HB330 (Illustrated on page 67)

Width at top: 220mm (8¾")
Width at base: 280mm (11")
Height: 430mm (17")
Weight: 42kg (93 lb)



Eastwell Fountain C200

See also, the Eastwell Urn A260 on page 29. For pedestal see Winslow Pedestal B350 on page 60.

Width at top: 785mm (31")
Width at base: 350mm (13¾")
Height: 595mm (23½")
Weight: 89kg (195 lb)
Recommended pump: X210



Figured Fountain C220

Shown raised on an optional Jacobean Pedestal B150 (see page 62) to create a stunning centrepiece fountain. See also Jacobean Sundial (page 65) and Figured Bird Bath (page 68).

Bowl diameter: 520mm (20½")
Height: 710mm (28")
Weight: 73kg (161 lb)
Recommended pump: X220



Triple Dolphin Fountain C1700 inc Pedestal C180

Three dolphins set on a pedestal as a fountain centrepiece. See also, Lotus Bowl page 94.

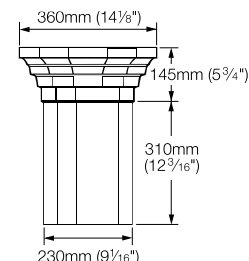

Pedestal C180

Dolphin height: 510mm (20")
Dolphin weight: 15kg (33 lb)
Pedestal weight: 35kg (77 lb)

Recommended pump: X220

TS Tech Sheet No. F22

GARDEN & LANDSCAPE FOUNTAINS - POOL SURROUNDS

Haddonstone pool surrounds are available in numerous combinations of kerb, vase and plinth sections to suit individual requirements. There are six standard sizes: HALF SMALL, SMALL, MEDIUM, LARGE, EXTRA LARGE and EXTRA EXTRA LARGE.

Straight pool components, including corners, are also available:

TS Tech Sheet No. P60 & P50

The vase section, which is in the shape of a conch shell, flanked by two dolphins, is supported by a base decorated with palmettes and scrolls. It can be used as a fountain, a planter, or both.

The kerb section has a continuous moulding enriched with ovolo and palmette designs.

The plinth lends appeal to the overall appearance of the pool, raising it from ground level.

Tech Sheets for pool assembly and recommended plumbing layout drawings are available on request. Plumbing Tech Sheets are:

TS Tech Sheet No. P42 for Half Small Pool

TS Tech Sheet No. P12 & P41 for Small Pool

TS Tech Sheet No. P11 & P12 for M, L, XL & XXL

For details of centrepiece fountains, see pages 91-96.

Glass fibre pool liners are available for the Half Small and Small pools only. Larger pools should be lined with a water-proofed render. Both are shown as typical sections, see page 98. Alternatively butyl liners may be used.

Please note that the use of a shallow liner in a Small or Half Small pool precludes the plumbing of vases. A plinth course is required to allow the use of a shallow liner.

Typical average weights:
Kerb sections: 31kg (68 lb)
Vase sections: 40kg (88 lb)
Kerb plinth: 31kg (68 lb)
Vase plinth: 50kg (110 lb)

Simple precautions should be taken to avoid frost damage to fountains. Water should be drained off before winter every year and not replaced until spring when any risk of hard frost has passed.

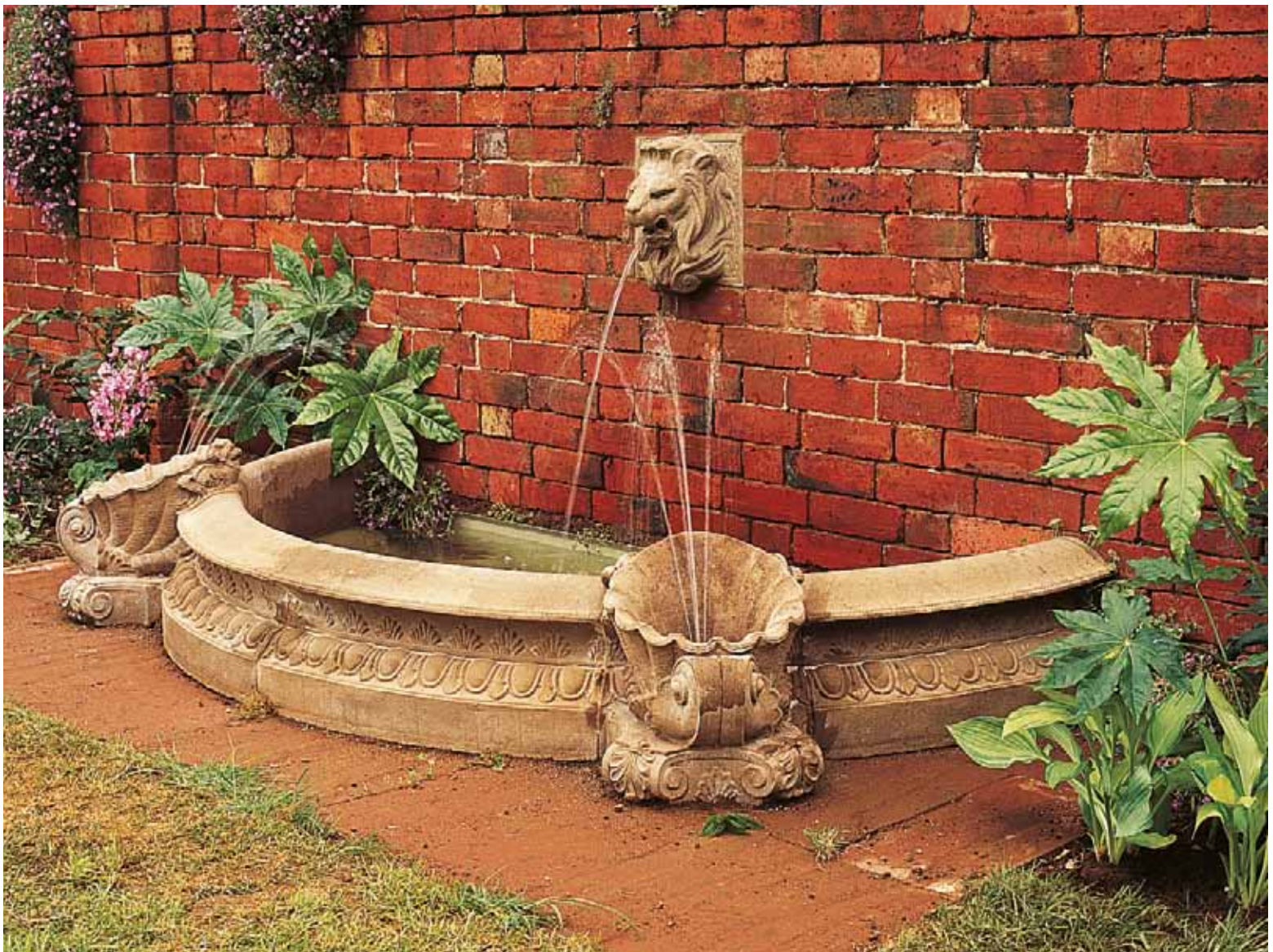

Half-Small Pool Surround C4HSKV illustrated without plinths (internal diameter 1780mm, 70") showing Lion Wall Fountain

TS Tech Sheet No. P40

PUMPS AND PLUMBING

Pool surrounds
Pumps and plumbing extra
– see price list.

Centrepiece and wall fountains,
excluding Haddonstone Wall
Fountain
Plumbing included. Pumps extra
– see price list.

Self-circulating fountains,
including Haddonstone Wall
Fountain
Pumps and plumbing included.

Please note:
Haddonstone's plumbing kits
do not necessarily produce the
effects shown in the catalogue.
Details of standard and special
effect fountain jets are available
on request.

Small Pool Surround C4SKVP
(internal diameter 1780mm, 70")
showing Regency Fountain and
Pedestal. For standard fountain jet,
see page 101.

TS Tech Sheet No. P40



Medium Pool Surround C4MKVP (internal diameter 2705mm, 106½") showing Neapolitan Fountain

TS Tech Sheet No. P30 & P50

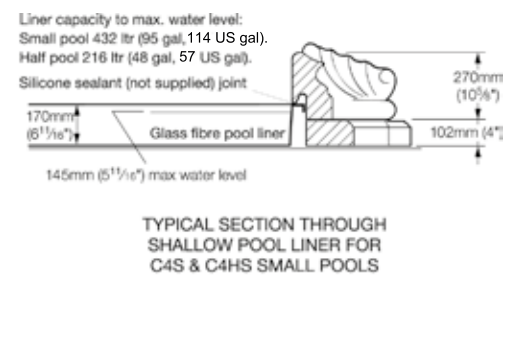
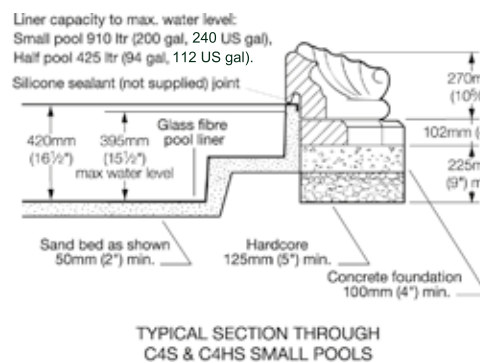
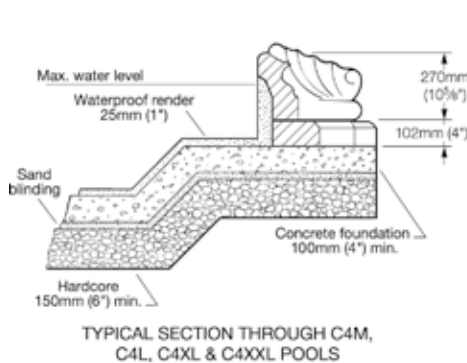

GARDEN & LANDSCAPE FOUNTAINS - POOL SURROUNDS

Large Pool Surround C4LKVP
(internal diameter 3660mm, 144")
showing Figured Fountain and
Jacobean Pedestal with special
effect fountain jet

TS Tech Sheet No. P20 & P50



Barton Grange Garden Centre, Lancashire

Extra Large Pool Surround C4XLKP illustrated without vases
(internal diameter 5450mm, 214½") showing Triple Lotus Bowl Fountain

TS Tech Sheet No. P10 & P50



Contractor: The Company of Landscapers

Extra Extra Large Pool Surround C4XXLKP illustrated without vases
(internal diameter 7500mm, 295") showing Triple Dolphin Fountain and
Pedestal in Lotus Bowl with special effect fountain jet

TS Tech Sheet No. P80 & P50

POOL TYPE	INSIDE DIAMETER	OUTSIDE DIAMETER KERB *	OUTSIDE DIAMETER KERB PLINTH **	WITH VASE SECTIONS					WITHOUT VASE SECTIONS			POOL LINER AVAILABLE	
				C400 KERB	C420 VASE	C440 KERB PLINTH	C441 HALF PLINTH	C460 VASE PLINTH	WEIGHT	C400 KERB	C440 KERB PLINTH		WEIGHT
C4HS HALF SMALL POOL	1780mm (70")	2100mm (82¾")	2306mm (90¾")	4	2	1	2	2	408kg (900 lb)	5	4	310kg (684 lb)	YES
C4S SMALL POOL	1780mm (70")	2100mm (82¾")	2306mm (90¾")	8	4	4	-	4	817kg (1800 lb)	10	8	620kg (1367 lb)	YES
C4M MEDIUM POOL	2705mm (106½")	3025mm (119¼")	3235mm (127½")	12	6	6	-	6	1078kg (2376 lb)	15	12	809kg (1784 lb)	NO
C4L LARGE POOL	3660mm (144")	3980mm (156¾")	4190mm (165")	16	8	8	-	8	1303kg (2872 lb)	20	16	958kg (2112 lb)	NO
C4XL EXTRA LARGE POOL	5450mm (214½")	5770mm (227¼")	5980mm (235½")	24	12	12	-	12	1968kg (4338 lb)	30	24	1506kg (3320 lb)	NO
C4XXL EXTRA EXTRA LARGE POOL	7500mm (295")	7820mm (308")	8030mm (316")	28	14	14	-	14	2587kg (5703 lb)	35	28	1974kg (4352 lb)	NO

* EXCLUDES VASES ** EXCLUDES VASES AND PLINTHS. REFER TO TECHNICAL SHEETS FOR DETAILS.

GARDEN & LANDSCAPE FOUNTAINS - POOL SURROUNDS

Detail of a pool showing Haddonstone straight and outside corner pool sections featuring non-standard dolphin fountains. Straight kerb and plinth sections are supplied in 660mm (26") lengths. Inside and outside corners, vases and plinths are also available.

TS Tech Sheet No. P60



Client: London Borough of Kensington and Chelsea

Pool and planting display using standard small and large Haddonstone pool surrounds.



Torus Pool Surround showing West Lodge Fountain.

Torus Pool Surround **HC485**

A simple bull-nosed pool surround which can be used in conjunction with a Haddonstone standard Pool Liner and paving or flooring. Ideal for contemporary garden designs.

Internal diameter: 1720mm (67³/₄"")
 External diameter: 2320mm (91³/₈"")
 Thickness: 50mm (2")
 Weight (per slab): 25kg (55 lb)
 Total weight: 200kg (440 lb)



Roman Pool Surround (Small) C470S showing Eastwell Fountain

TS Tech Sheet No. P100, P105 & P110

Roman Pool Surround

This design extends the range of Haddonstone's pool surrounds. The design features a bold roll moulding and the flat coping forms a low sitting place. Also available are straight and corner stones allowing pools of differing shapes to be made. Glass fibre pool liners are available for the Half Small and Small pools only.

Height: 380mm (15")
 Internal radius: 900mm (35 1/2")
 Ext. radius (base): 1080mm (42 1/2")
 C470S weight: 788kg (1738 lb)
 C470HS weight: 394kg (869 lb)

ROMAN POOL TYPE	INSIDE DIAMETER (BASE)	OUTSIDE DIAMETER (BASE)	C470 KERB SECTIONS	WEIGHT	POOL LINER AVAILABLE
C470HS HALF SMALL POOL	1800mm (70 7/8")	2160mm (85")	5	394kg (869 lb)	YES
C470S SMALL POOL	1800mm (70 7/8")	2160mm (85")	10	788kg (1738 lb)	YES
C470M MEDIUM POOL	2770mm (109 1/16")	3100mm (122")	15	1095kg (2412 lb)	NO
C470L LARGE POOL	3470mm (136 1/16")	3800mm (149 5/8")	18	1350kg (2974 lb)	NO

Roman Pool Straight Stone C4706

Height: 380mm (15")
 Length: 500mm (19 3/4")
 Weight: 64kg (141 lb)

Roman Pool Outside Corner Stone C4707

Height: 380mm (15")
 Length: 250mm (9 3/4")
 Weight: 45kg (99 lb)

Roman Pool Inside Corner Stone C4708

Height: 380mm (15")
 Outside base length: 415mm (16 1/4")
 Weight: 90kg (198 lb)

GARDEN & LANDSCAPE FOUNTAINS - POOL SURROUNDS



Pebble Pool X435 (Shown with Neapolitan Small Double Fountain)

In response to numerous requests from clients, Haddonstone has introduced this sturdy pebble pool for digging into the ground, which can be used in conjunction with the following fountains:

- C172 Large Dolphin Fountain on S310S Support, see page 91
- C300 Lion Fountain on C305 Base, see page 91
- HC390 Water Nymph on A240 Plinth, see page 91
- C200 Eastwell Fountain on B350 Pedestal, see page 96
- HC510 Regency Fountain on HB330 Pedestal, see page 96
- C3650 Neapolitan Small Double Fountain (shown), see page 92
- C3700 Neapolitan Fountain, see page 92

This robust pebble pool is manufactured from 100% recycled plastic and can be used without formal raised pool surrounds.

For dimensions, please refer to the diagram. Pebbles not supplied.



Pool Coping T770

As well as straight stones, inside and outside and 135° corner stones are available:

Weight: 63kg (139 lb) per 914mm (36")

Length: 914mm (36")

Inside and Outside Corner coping:

Size: 650mm x 650mm (25 1/2" x 25 1/2") overall

TS Tech Sheet No. P70

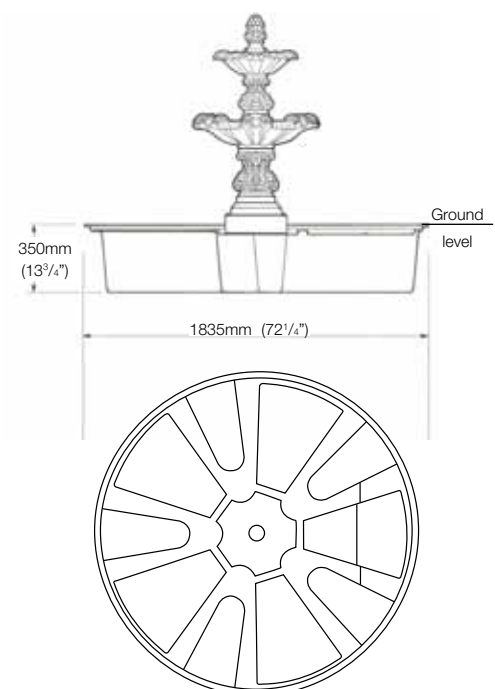
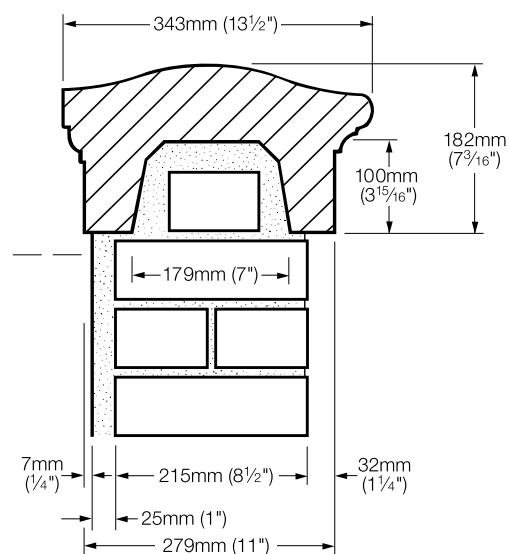

Please refer to our price list for details of fountains, pumps and plumbing.

GARDEN & LANDSCAPE LIGHTING (UK only)

Haddonstone Ltd is able to offer lighting suitable for pool surrounds, fountains and gardens. The 12-volt system uses a transformer which can be submerged. As the transformer can be operated underwater, this enables long distances between the mains socket and the transformer to be bridged with conventional cables. Units can be connected to each transformer up to a maximum of 150 watts. A variety of other lighting effects and control systems are available. Please ask for details.

Jubilee Pool Surround C4801

Inspired by a pool surround in Haddonstone's Jubilee Show Garden in Northamptonshire, this design is intended to provide a simple surround for smaller water features.

This design can sit on an existing terrace or patio as it requires no additional excavation. Illustrated with the C3750 Small Neapolitan Fountain centrepiece (see page 92).

Outside base diameter: 1470mm (57⁷/₈"

Height: 215mm (8¹/₂"

Weight: 212kg (467 lb)

TS Tech Sheet No. P95



Arcadian Half Pool Surround GC405

Includes pool liner and cable gland. (Surround supplied in 4 sections). For Green Man Wall Fountain GC500A, see page 114.

Width: 1470mm (58") Projection: 735mm (29") Weight: 118kg (259 lb)



Lunaqua 10 (UK only)

A very versatile lighting system, which can be used either underwater or in a normal garden setting. The 50 watt spotlights are connected to the transformer via special plug-in connectors.

The spotlight is made of shockproof plastic with an integral swivel bracket allowing it to be turned through 180°, the angle of beam being 24°.

GARDEN & LANDSCAPE FOUNTAINS - SELF CIRCULATING

Small Lagoon Fountain **HC380** (not illustrated)

Lagoon Fountain **HC383**

Large Lagoon Fountain **HC385** (not illustrated)

New to the Haddonstone Collection, these impressive self-circulating fountains would add style to either a private garden or a commercial project. These designs are also available as planters, see page 55.

	HC380	HC383	HC385
Height:	600mm (23 ⁵ / ₈ "	600mm (23 ⁵ / ₈ "	600mm (23 ⁵ / ₈ "
Top width:	1220mm (48")	1570mm (61 ³ / ₄ "	1775mm (69 ⁷ / ₈ "
Weight:	535kg (1178 lb)	857kg (1888 lb)	1092kg (2405 lb)

Please note: HC385 will require mechanical lifting on site in all instances.



Romanesque Fountain TLHC521

Adapted from the Romanesque Bowl (see page 29), this low-level fountain bowl can provide an attractive self-circulating water feature to decorate any small interior or exterior setting. Includes pump. Shown with Brass Rose Jet X270, included.

Diameter: 815mm (32")

Height: 348mm (13¹/₁₆"

Weight: 67kg (148 lb)

Versailles Fountain HC800

The design for this self-circulating fountain was inspired by the fountains within the renowned Bosquet de la Colonnade at Versailles. Ideally suited for interior and exterior settings ranging from terraces and kitchen gardens to conservatories and hotel foyers. Includes pump and Brass Rose Jet X270.

Width of bowl: 913mm (36")

Overall width of base: 675mm (26¹/₂"

Height: 390mm (15³/₈"

Weight: 185kg (407 lb)

General Note: Simple precautions should be taken to avoid frost damage to fountains. Water should be drained off before winter every year and not replaced until spring when any risk of hard frost has passed.



Bayeux Fountain HC130

Inspired by Romanesque architecture, this robust self-circulating fountain features stylish leaf moulding around the fountain bowls. This design was created by Haddonstone to act as a focal point in a sheltered garden or conservatory. See page 111 for Bayeux Wall Fountain.

Includes pump.

Diameter of main bowl: 950mm (37³/₈"

Diameter of base: 572mm (22¹/₂"

Overall height: 1525mm (60")

Weight: 222kg (489 lb)

Heaviest component: 147kg (323 lb)

Please note: will require mechanical lifting on site in all instances



Andalos Fountain C100

The twelve-sided bowl displays an hexagonal Arabesque decoration, whilst the hexagonal base has a twelve-sided decoration. Rhythmical repetition of horseshoe arches suggests the fountain could have originated in a mosque complex. Includes pump. Jardiniere available, see page 44.

Width at rim: 725mm (28½")
 Width at base: 560mm (22")
 Height: 770mm (30¼")
 Weight: 171kg (377 lb)



Bay Fountain HC185

The Bay Fountain is a new addition to the Haddonstone Collection. This stylish self-circulating fountain is ideal for enhancing a contemporary garden or landscape. Includes pump. Also available as a planter, see page 55.

Height: 400mm (15¾")
 Width at top: 1850mm (72⅞")
 Weight: 690kg (1520 lb)

Gothic Fountain C251

Upper Base A350
 Lower Base A360

Illustrated as a freestanding fountain with optional Gothic Upper Base. It can also be supplied with an optional Lower Base. For diagram see Gothic Jardiniere on page 45. Supplied with offset cable hole unless specified. Includes pump.

Fountain width: 800mm (31½")
 Fountain height: 660mm (26")
 Fountain weight: 224kg (494 lb)

TS Tech Sheet No. F75



GARDEN & LANDSCAPE FOUNTAINS - SELF CIRCULATING

Eclipse Fountain GC230

Table-top fountain.
Includes pump.

Height: 285mm (11¼")
Diameter: 305mm (12")
Weight: 26kg (57 lb)



Crucible Fountain GC200

Includes pump.

Crucible planter also available,
see page 52.

Height: 620mm (24¾")
Width: 500mm (19¾")
Weight: 105kg (231 lb)



Original design concept: Alfresco Garden Furnishings



Lotus Bud Fountain GC320 Includes pump.

Will need topping up regularly - not suitable for continuous unattended running. Large bowl requires mechanical lifting on site in all instances.

Height: 1600mm (63")
Max diameter: 1125mm (44¼")
Total weight: 582kg (1280 lb)
Heaviest component: 267kg (587 lb)



Arcadian Double Fountain GC300 Includes pump.

Will need topping up regularly - not suitable for continuous unattended running.

Height: 1155mm (45½")
Max width: 845mm (33¼")
Total weight: 170kg (374 lb)
Heaviest component: 73kg (161 lb)

GARDEN & LANDSCAPE FOUNTAINS - SELF CIRCULATING

Haddonstone launched the Pebble Bowl concept to enable fountains to be positioned in places where excavation is not possible, or desirable - making Pebble Bowls ideal for patios or garden rooms.

Each Pebble Bowl is also available with an optional GC710C Pebble Bowl Support to raise the fountain off the ground, see below left.

Each fountain centrepiece is also available with a robust Pebble Pool, which requires excavation, as follows:
X465 Pebble Pool [650mm (25½") diameter, 305mm (12") depth] or X460/X461 Pebble Pool [ovoid 1010 x 820mm (39¾" x 32¼"), 410mm (16") depth]. See diagrams right, Ammonite Fountain GC101 shown.

The appropriate Pebble Pool is identified alongside each product description where relevant.

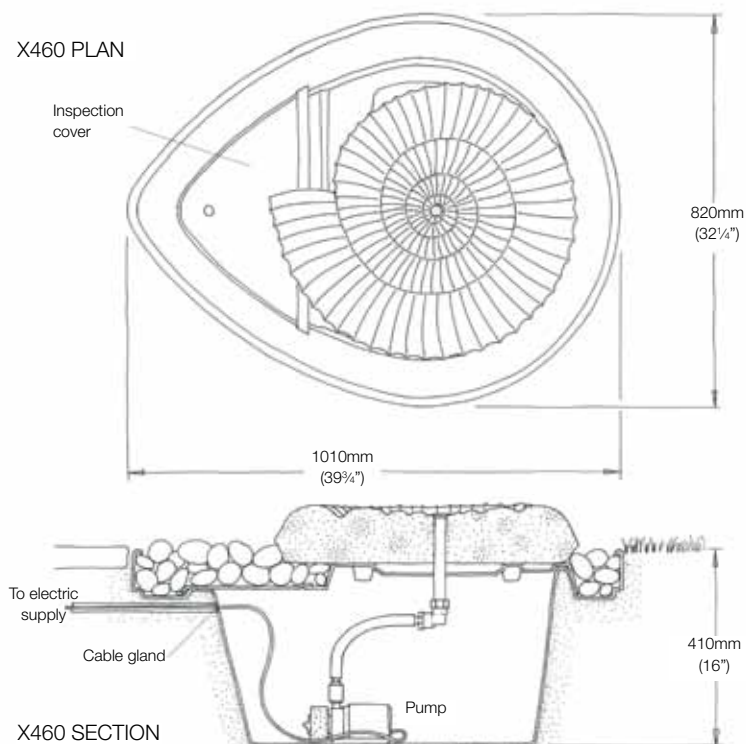

Pebble Bowl Support GC710C

Shown with Lotus Flower Pebble Bowl Fountain, see page 109, (not included).
Optional for all Arcadian Pebble Bowl Fountains.

Height: 210mm (8¼")
Overall diameter: 420mm (16½")
Weight: 39kg (86 lb)



AquaStack Fountain GC191 (with 7 sections)

Includes pump and X465 Pebble Pool. Pebbles not supplied.

Height of stone: 380mm (15")
Length of each section:
315mm (12⅜")
Total weight: 27kg (59 lb)

General Note: The innovative AquaStack system enables customers to build their own fountains by choosing the number of GC190A sections required - each being fitted over a central copper pipe at the preferred angle. GC190A height: 40mm (1⅞")



AquaStack Pebble Bowl Fountain GC194 (with 12 sections)

Includes pump. For optional Pebble Bowl Support, see GC710C left.

Overall height: 650mm (25⅝")
Bowl width: 720mm (28½")
Total weight: 84kg (185 lb)
Heaviest component: 42kg (93 lb)

Ammonite Fountain GC101

Includes pump and X460 Pebble Pool. Pebbles not supplied.
Not available as a Pebble Bowl Fountain.

Height of stone: 120mm (4³/₄"")
Width of stone: 625mm (24¹/₂"")
Weight of stone: 53kg (116 lb)



Lotus Flower Pebble Bowl Fountain GC143

Includes pump. For optional Pebble Bowl Support, see page 108.

Overall height: 315mm (12³/₈"")
Bowl width: 720mm (28¹/₂"")
Total weight: 80kg (176 lb)
Heaviest component: 42kg (93 lb)

Lotus Flower Fountain GC141 (not illustrated)

Includes pump and X465 Pebble Pool.

Height of stone: 145mm (5³/₄"")
Width of stone: 500mm (19³/₄"")
Weight of stone: 32kg (70 lb)



Spiral Egg Pebble Bowl Fountain GC123

Includes pump. For optional Pebble Bowl Support, see page 108.

Overall height: 670mm (26³/₈"")
Bowl width: 720mm (28¹/₂"")
Total weight: 130kg (286 lb)
Heaviest component: 80kg (176 lb)

Spiral Egg Fountain GC121 (not illustrated)

Includes pump and X465 Pebble Pool.

Height of stone: 500mm (19³/₄"")
Max. width of stone: 380mm (15")
Weight of stone: 80kg (176 lb)

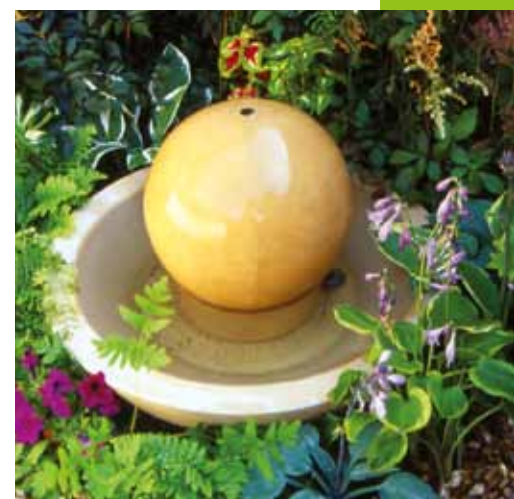

Ball Pebble Bowl Fountain GC163

Includes pump. For optional Pebble Bowl Support, see page 108.

Overall height: 525mm (20⁵/₈"")
Bowl width: 720mm (28¹/₂"")
Total weight: 97kg (214 lb)
Heaviest component: 47kg (104 lb)

Ball Fountain GC161 (not illustrated)

Includes pump and X465 Pebble Pool.

Diameter of stone: 355mm (14")
Weight of stone: 47kg (104 lb)

GARDEN & LANDSCAPE FOUNTAINS - SELF CIRCULATING

Triple Ball Fountain GC162

Includes pump, plumbing and X461 Pebble Pool. Glass beads not supplied. Not available as a Pebble Bowl Fountain.

Max height of stone: 355mm (14")
Total weight: 124kg (273 lb)
Heaviest component: 47kg (104 lb)



Ring Maze Fountain GC181

Includes pump and X465 Pebble Pool. Pebbles not supplied.

Height of stone: 80mm (3 1/8")
Max. width of stone: 540mm (21 1/4")
Weight of stone: 27kg (59 lb)

Ring Maze Pebble Bowl Fountain GC183 (not illustrated)

Includes pump. For optional Pebble Bowl Support, see page 108.

Overall height: 230mm (9")
Bowl width: 720mm (28 1/2")
Total weight: 76kg (167 lb)
Heaviest component: 42kg (93 lb)



Spiral Tower Pebble Bowl Fountain GC157

Includes pump. For optional Pebble Bowl Support, see page 108.

Overall height: 870mm (34 1/4")
Bowl width: 720mm (28 1/2")
Total weight: 104kg (229 lb)
Heaviest component: 62kg (137 lb)

Spiral Tower Fountain GC156 (not illustrated)

Inc. pump and X460 Pebble Pool.

Height of stone: 800mm (31 1/2")
Base width of stone: 200mm (7 7/8")
Overall width of stone: 250mm (9 7/8")
Weight of stone: 62kg (137 lb)



Arcadian Single Fountain GC131

Includes pump and X460 Pebble Pool. Pebbles not supplied. Not available as a Pebble Bowl Fountain.

Height of stone: 470mm (18 1/2")
Max width of stone: 457mm (18")
Weight of stone: 27kg (59lb)

GARDEN & LANDSCAPE FOUNTAINS - WALL

Haddonstone Wall Fountain HC270

A delightful wall fountain, of neoclassical design. The bowl is supported by a tapered, fluted pedestal with a spiralling ribbon design. Ideal as a wall decoration on a terrace or in a conservatory or hotel foyer. This design can be installed on most existing walls. Includes pump.

Height: 1650mm (65")
Shell projection: 410mm (16 $\frac{1}{8}$ "")
Width overall: 720mm (28 $\frac{1}{4}$ "")
Weight: 126kg (278 lb)

(Registered Design No. 2046016)

TS Tech Sheet No. F60



Haddonstone Wall Fountain HC271

This delightful wall fountain is a variation on the HC270, see above. It has been designed to allow for face fixing to most existing walls via an ingenious combination of concealed dowels and a wrought iron strap. Includes pump.

Height: 1065mm (42")
Shell projection: 410mm (16 $\frac{1}{8}$ "")
Width overall: 720mm (28 $\frac{1}{4}$ "")
Weight: 95kg (209 lb)

TS Tech Sheet No. F61

Bayeux Wall Fountain HC135

A self-circulating, wall mounted version of the Bayeux Fountain (see page 105).

Includes pump

Projection from wall: 480mm (18 $\frac{7}{8}$ "")
Width of bowl: 950mm (37 $\frac{3}{8}$ "")
Width of base: 572mm (22 $\frac{1}{2}$ "")
Overall height: 1525mm (60")
Weight: 134kg (295 lb)
Heaviest component: 48kg (106 lb)

GARDEN & LANDSCAPE FOUNTAINS - WALL

Shell Wall Fountain HC540

A beautiful formalised, scalloped shell forms the bowl of this wall fountain, supported by a boldly voluted console. Illustration shows Shell Wall Fountain HC540 and Console HC550 with Dolphin C170 and Console C160.

Width: 760mm (30")
Shell projection: 650mm (25½")
Height of shell and console: 785mm (31")
Weight: 165kg (363 lb)

Please note that a 215 mm (8½") minimum wall thickness is required for this ensemble. Coping details available on request.

Recommended pump: X220

TS Tech Sheet No. F10 & F11



Grotesque Mask E340 Grotesque Wall Fountain C260 (Not illustrated)

A vigorous comic mask.
Height: 265mm (10½")
Width: 230mm (9")
Weight: 8kg (17 lb)

Recommended pump: X210



Lion Wall Fountain C310 Lion Wall Mask E470 (Not illustrated)

A handsome lion mask mounted on a square stone. Designed to be built into a wall.

Height of stone: 290mm (11½")
Width of stone: 290mm (11½")
Height of mask: 315mm (12½")
Weight: 15kg (33 lb)

Recommended pump: X210

TS Tech Sheet No. F40 & M59

Also available: Large Lion Mask HE475. Height: 1000mm (39¾"), Weight: 570kg (1255 lb)



Large Lion Wall Fountain C315

Designed by Haddonstone in the style of the antique, this robust wall fountain features a lion with a flowing mane.

Width: 452mm (17¾")
Depth: 170mm (6¾")
Weight: 24kg (53 lb)

Recommended pump: X220



Wood Nymph Wall Fountain C320

Mounted on a square stone, this charming new wall fountain is designed to be built into a wall. As shown, it also provides an alternative to the Lion Wall Fountain when used in conjunction with the C531 Dauphin Fountain.

Width of stone: 295mm (11⅝")
Height of stone: 295mm (11⅝")
Width of mask 320mm (12½")
Height of mask: 480mm (19")
Weight: 24kg (52 lb)

Recommended pump: X210

Dauphin Fountain

C530

Designed in the continental style, this attractive self circulating fountain features a handsome lion mask together with bold scroll details. The half octagonal pool conceals a glass fibre liner. Includes pump. Shown with Swagged Roundel (page 186), Ionian Jardinières (page 40) and Copings, Strings and Bosses (page 112).

Width: 1180mm (46½")

Depth: 700mm (27½")

Height: 1460mm (57½")

Weight: 430kg (947 lb)

TS Tech Sheet No. F65

Dauphin Fountain

C531 (Not illustrated)

Incorporating the charming Wood Nymph Wall Fountain, see page 112.



GARDEN & LANDSCAPE FOUNTAINS - WALL

Gecko Bowl Fountain GC531

Incorporating GC750 Bowl & pump.

Height overall: 595mm (23 1/2")
Stone width overall: 350mm (13 3/4")
Total weight: 29kg (64 lb)
Heaviest component: 21kg (46 lb)

Gecko Wall Fountain GC530A

Stone only. Recom. pump: X190.

Height overall: 345mm (13 5/8")
Width at top: 270mm (10 5/8")
Weight: 7kg (15 lb)



Green Woman Bowl Fountain GC541

Incorporating GC755 Bowl.
Includes pump.

Height overall: 750mm (29 1/2")
Bowl width: 480mm (18 7/8")
Total weight: 54kg (119 lb)
Heaviest component: 34kg (75 lb)

Green Woman Wall Fountain GC540A

Stone only. Recom. pump: X206.

Diameter: 400mm (15 3/4")
Thickness: 100mm (3 7/8")
Weight: 17kg (37 lb)

Registered Design No: 2104236



Tree Frog Bowl Fountain GC551

Incorporating GC755 Bowl.
Includes pump.

Height overall: 750mm (29 1/2")
Bowl width: 480mm (18 7/8")
Total weight: 54kg (119 lb)
Heaviest component: 34kg (75 lb)

Tree Frog Wall Fountain GC550A

Stone only. Recom. pump: X206.

Diameter: 400mm (15 3/4")
Thickness: 100mm (3 7/8")
Weight: 17kg (37 lb)



Medusa Bowl Fountain GC521

Incorporating GC750 Bowl, see
above. Includes pump.

Height overall: 595mm (23 1/2")
Stone width overall:
350mm (13 3/4")
Total weight: 29kg (64 lb)
Heaviest component: 21kg (46 lb)

Medusa Wall Fountain GC520A

Stone only. Recom. pump: X190.

Height overall: 345mm (13 5/8")
Width at top: 270mm (10 5/8")
Weight: 7kg (15 lb)



Green Man Bowl Fountain GC501

Incorporating GC750 Bowl, see
above. Includes pump.

Height overall: 560mm (22")
Stone width overall:
350mm (13 3/4")
Total weight: 28kg (62 lb)
Heaviest component: 21kg (46 lb)

Green Man Wall Fountain GC500A

Stone only. Recom. pump: X190.

Width of stone: 220mm (8 3/4")
Height of stone: 280mm (11")
Weight of stone: 5kg (11 lb)

GARDEN & LANDSCAPE PLAQUES

Griffin Plaque TLQ994

Dating from the late eighteenth century, this replica of a famous Coade design is ideal for enhancing a classical architectural scheme. Can be built-in or face-fixed with mechanical fixings.

Width: 1228mm (48³/₈"")

Height: 890mm (35¹/₁₆"")

Depth of block: 65mm (2⁹/₁₆"")

Weight: 76kg (167 lb)



Spring Plaque TLQ990 Autumn Plaque TLQ992

Summer Plaque TLQ991 Winter Plaque TLQ993

The charming Seasons Plaques depict putti with their seasonal attributes: garlands of flowers; sheaves of corn; cornucopia of fruit; and, fire and ice. These are faithful reproductions taken from original designs created by the renowned Coade manufactory.

Width: 890mm (35¹/₁₆"") Height: 440mm (17⁵/₁₆"") Depth of block: 20mm (3/4") Weight: 22kg (48 lb)



Tradescant Wall Plaque Q660

Based on an XVII century plaque displayed at the Museum of Garden History. Recarved to depict John Tradescant (1608-1662), gardener to Charles II and famous for bringing numerous plant species to England, including many from America. Up to two letters or numerals may be cast into the stone either side of the figure (i.e. four in total).

Height: 695mm (27³/₈"")

Width: 555mm (21⁷/₈"")

Depth: 135mm (5⁵/₁₆"")

Weight: 65kg (143 lb)

(Registered Design No. 2061157)

GARDEN & LANDSCAPE PLAQUES & ACCENTS

Capturing the majesty of the renowned Parthenon Frieze, this pair of designs is replicated from original carvings which date from c443-438 BC. The originals depict the Panathenaic Procession. These horsemen are from the north frieze. Available individually or as a pair. All dimensions are approximate owing to the shape of the originals. Will require mechanical fixing in most instances.

Parthenon Frieze I [TLQ981](#)

Width: 1250mm (49¼")
Depth: 100mm (4")
Height: 1030mm (40½")
Weight: 150kg (330 lb)



Parthenon Frieze II [TLQ982](#)

Width: 1250mm (49¼")
Depth: 100mm (4")
Height: 1030mm (40½")
Weight: 150kg (330 lb)



Celtic Stepping Stone - Knotted [GN100A](#)

See right (left). Complements Celtic Edging, see page 120.

Diameter: 355mm (14")
Weight: 7.5kg (17 lb)

Celtic Disc [GN500A](#)

See right (centre). Can be used with Celtic Stepping Stones, see below. Complements Celtic Edging, see page 120.

Diameter: 600mm (23⅝")
Weight: 25kg (55 lb)

Celtic Stepping Stone - Woven [GN200A](#)

See right (right). Complements Celtic Edging, see page 120.

Diameter: 355mm (14")
Weight: 7.5kg (17 lb)



GARDEN & LANDSCAPE GARDEN DECOR & ACCENTS

Chimney Pot Planter HA217

Haddonstone replicated this intriguing chimney pot design for a restoration project. Now available as the Chimney Pot Planter, this rustic design should prove a popular addition to both cottage and urban gardens. The Chimney Pot Planter allows roots to reach the underlying soil as the design is produced without a base.

Height: 557mm (21¾")
 Length at base: 370mm (14⅝")
 Width at base: 298mm (11¾")
 Length at top: 343mm (13½")
 Width at top: 305mm (12")
 Weight: 20kg (44 lb)



Bollard D100

A simple bollard, ideal for contemporary or traditional schemes.

Width at base: 255mm (10")
 Height: 610mm (24")
 Weight: 50kg (110 lb)



Bollard D110

This bollard surmounted by a fir cone finial may be used with or without connecting chains (not supplied). Hooks available as an optional extra.

Width at base: 165mm (6½")
 Height above ground: 650mm (25½")
 Depth below ground: 315mm (12½")
 Height of fir cone: 180mm (7")
 Weight: 33kg (74 lb)



Mini Ammonite GE950

Cast from a genuine ammonite fossil, Mini Ammonites are versatile garden accents. They can be used underwater in a fountain, as a decorative edging or in a paving scheme or garden mosaic. Mini Ammonites are available individually or in packs of 20 (GE951).

Max width: 80mm (3⅛")
 Weight: 125g (2oz)



Staddle Stone E900

Staddle stones were originally used to raise grain stores off the ground, thereby stopping vermin from climbing up. Primarily associated with the Cotswolds, staddle stones can be used to flank drives or as garden ornaments. This design was produced in response to requests from clients.

Width at top: 450mm (17¾")
 Width at base: 300mm (11¾")
 Height: 640mm (25¼")
 Weight: 86kg (189 lb)

GARDEN & LANDSCAPE OBELISKS

EGYPTIAN IN ORIGIN, OBELISKS WERE BROUGHT TO ROME IN THE FIRST CENTURY BC. THE OBELISK THEN ENTERED INTO THE CLASSICAL VOCABULARY, BEING MODIFIED AND DEVELOPED INTO A DECORATIVE FEATURE IN THE ENGLISH LANDSCAPE FROM THE EIGHTEENTH CENTURY ONWARDS.

Ideal for formal or landscape gardens, defining a vista, at the centre of a courtyard or as a balustrade ornament.



Obelisk Finial
HE535

A charming small obelisk for use inside or out. Equally at home on a chimney piece hearth, a window cill, or in the garden.

Width of base: 150mm (6")
Height overall: 700mm (27½")
Weight: 14kg (31 lb)



Balustrade Obelisk
E545

This obelisk has been designed for positioning on a Haddonstone balustrade pier as an interesting alternative to an urn or finial. It may also act as a freestanding obelisk when used in conjunction with a B400, B420 or B440 plinth (see page 61).

Width at base: 152mm (6")
Height: 1005mm (39½")
Weight: 65kg (143 lb)

TS Tech Sheet No. M60



Gothic Obelisk
E540

An obelisk in Gothic style, ideally suited to form a focal point in a small garden.

Width of base: 460mm (18")
Height overall: 1800mm (71")
Weight: 262kg (578 lb)

TS Tech Sheet No. M21



Millennium Obelisk
E555

This imposing structure would make an impressive focal point in any major landscape project aimed at celebrating a unique event. Steps also available, see page 181.

Width of base: 1229mm (48¾")
Height overall: 6190mm (243¾")
Weight: 3750kg (8260 lb)

TS Tech Sheet No. M22

Obelisk E550

The Obelisk can be used to great effect at the end of a long vista, or in a courtyard or formal garden area.

Width of base: 700mm (27½")
Height overall: 2672mm (105¼")
Weight: 656kg (1446 lb)

TS Tech Sheet No. M20



GARDEN & LANDSCAPE LAWN EDGING

Celtic Edging

Inspired by Celtic designs, complementing the Celtic Disc and Stepping Stone, see page 116. Arched below ground for easy installation.

Celtic Edging GN750A

Length: 250mm (9³/₄"") Depth below ground: 100mm (4")
Width: 30mm (1¹/₈"") Weight: 3.5kg (8 lb)
Height above ground: 140mm (5¹/₂"")

Celtic Edging GN750B

Length: 495mm (19¹/₂"") Depth below ground: 100mm (4")
Width: 30mm (1¹/₈"") Weight: 7kg (16 lb)
Height above ground: 140mm (5¹/₂"")

Celtic Edging Post GN755A

Width: 40mm (1¹/₂"") Depth below ground: 100mm (4")
Height above ground: 185mm (7¹/₄"") Weight: 1kg (2 lb 3oz)



Scrolled Edging Stone D220

This edging has a scrolled front and plain back. Left and right-handed terminal lengths are 230mm (9"). Ideal for herbaceous borders.

Length: 457mm (18")
Height above ground: 90mm (3¹/₂"")
Depth below ground: 140mm (5¹/₂"")
Weight: 11.5kg (25 lb)

Edging Post D200

For corner or terminal use with Roped or Scrolled Edging.

Width: 75mm (3")
Height above ground: 120mm (4³/₄"")
Depth below ground: 140mm (5¹/₂"")
Weight: 2.5kg (5¹/₂ lb)



Roped Edging Stone D210

This edging, with its attractive rope decoration, is suitable for most situations and should be used with Edging Post D200.

Length: 452mm (17³/₄"")
Height above ground: 90mm (3¹/₂"")
Depth below ground: 135mm (5¹/₄"")
Weight: 9kg (21 lb)

Arcadian Lawn Edging

The unique Arcadian Lawn Edging system can be used as a mowing edge alongside flower borders, around a tree or as a kerb to paths or driveways.

Width: 140mm (5 1/2") Height: 90mm (3 1/2")



Outside Corner



External Curve

Straight GN700A

Length: 450mm (17 3/4") Weight: 8kg (18 lb)

Outside Corner GN700F

Length: 225mm (9") Weight: 6kg (13 lb)

Inside Corner GN700G

Length: 225mm (9") Weight: 6kg (13 lb)

Internal Curve GN700H-00500 (not USA)

External Curve GN700I-00500 (not USA)

Radius: 500mm (19 3/4") Complete circle 8 sections

Weight per section: 7kg (15 lb)

Internal Curve GN700H-01000 (not USA)

External Curve GN700I-01000 (not USA)

Radius: 1000mm (39 3/4") Complete circle: 12 sections

Weight per section: 10kg (22 lb)

External Curve GN700H-00036 (USA only)

Radius: 36" Complete circle: 14 sections Weight per section: 18 lb

External Curve GN700H-00072 (USA only)

Radius: 72" Complete circle: 27 sections Weight per section: 18 lb

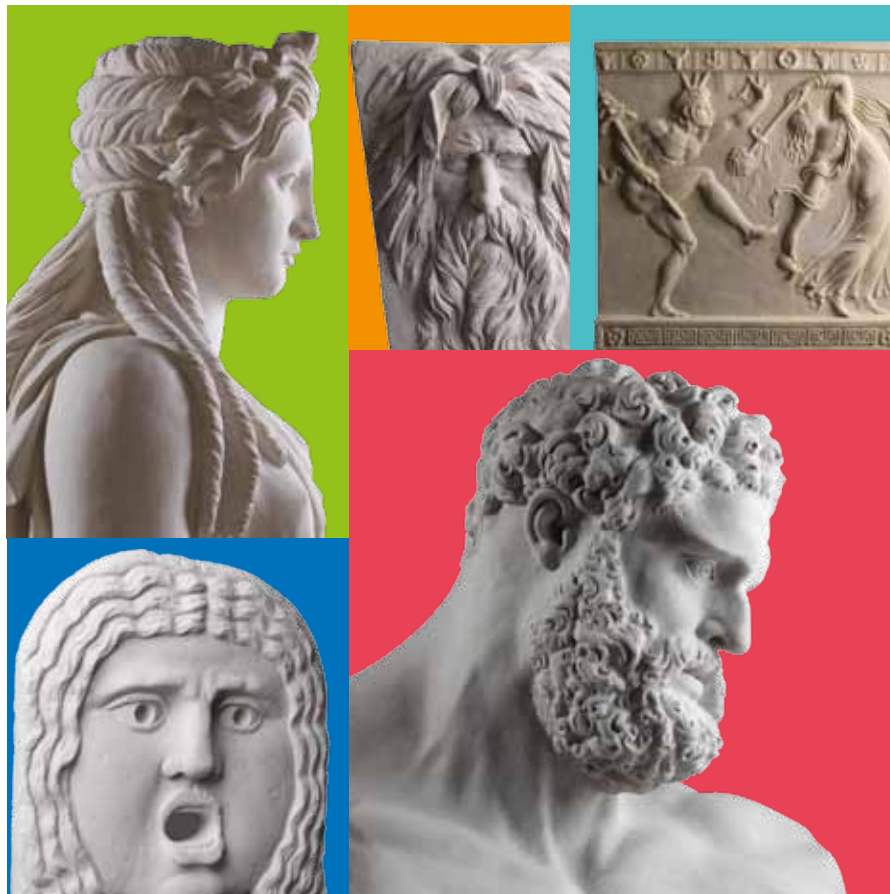

HADDONSTONE

Haddonstone Ltd,
The Forge House, East Haddon, Northampton NN6 8DB, England.
Telephone: 01604 770711 Fax: 01604 770027 info@haddonstone.co.uk

Haddonstone (USA) Ltd,
Telephone: 856 931 7011 Fax: 856 931 0040 info@haddonstone.com

Haddonstone (USA) Ltd,
32207 United Avenue, Pueblo, CO 81001, USA.
Telephone: 719 948 4554 Fax: 719 948 4285 stone@haddonstone.com

www.haddonstone.com