



Casting Designs, Inc.

Fort Worth, Texas

09290/CDI
BuyLine 5892

Glass Fiber Reinforced Gypsum and Concrete



- Column Covers
- Pilasters
- Domes
- Vaults
- Mouldings
- Light & Reflector Coves
- Cornice

From our manufacturing plant in Fort Worth, Texas, CDI produces and ships products worldwide. CDI provides custom architectural products for interior and exterior applications. We supply material for shopping malls, retail outlets, cultural enters, medical facilities, churches, university, schools, casinos and residential projects. Pictures in this brochure exemplify our craftsmanship, quality, pride, and ability to supply all your GRG and GRFC requirements.



▲ Conference Room, Corporate Headquarters

▼ State Capitol Building, Austin, TX



▼ St. Martin Episcopal Church, Houston, TX

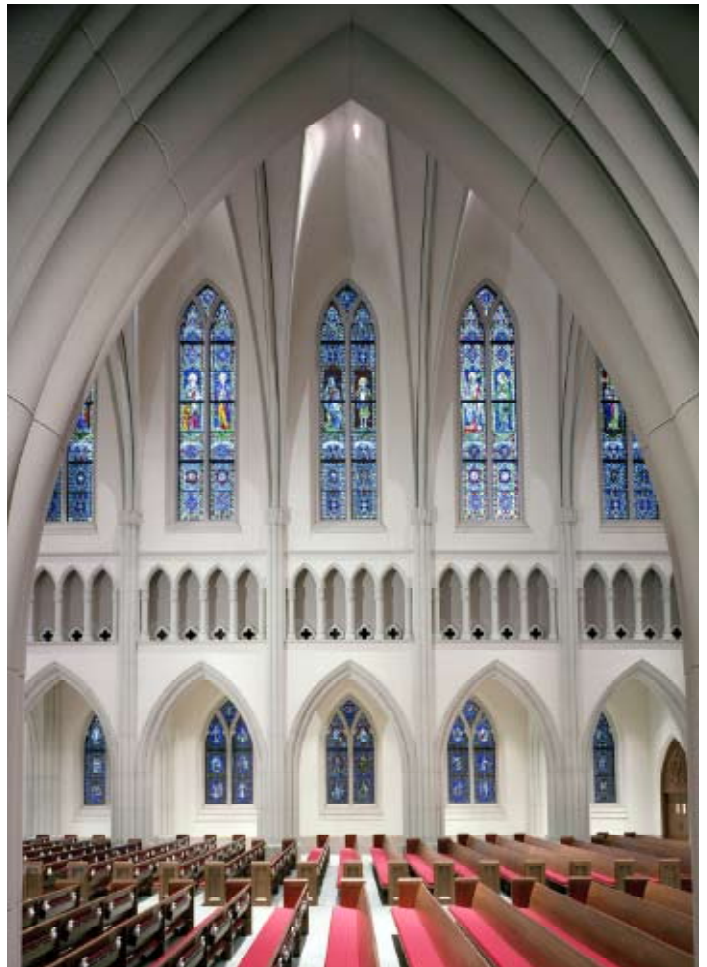



▲ Rice University, Houston, TX



▲ Beeson School of Divinity, Samford University, Birmingham, AL

▼ First Pentecostal, Little Rock, AR

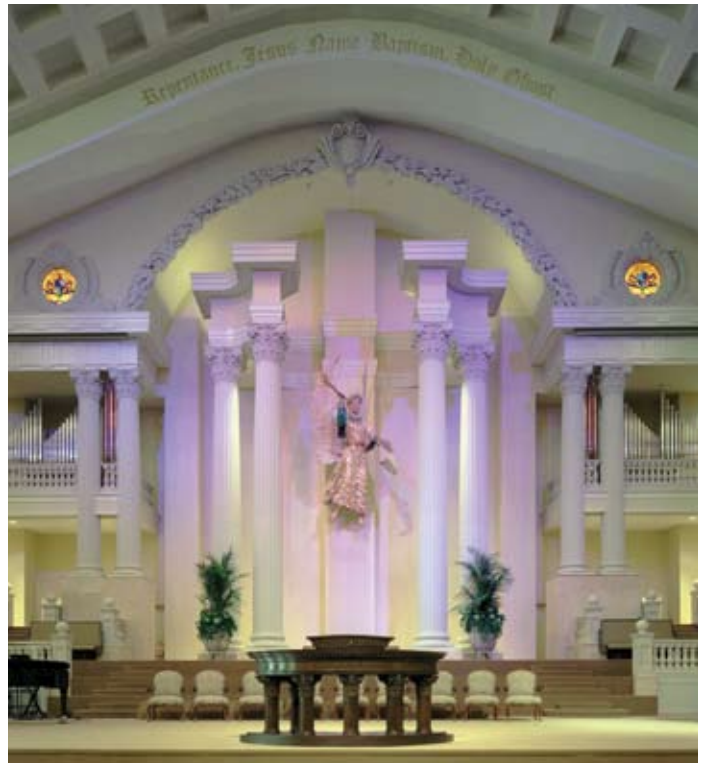



▲ Exterior Round Stacking Columns

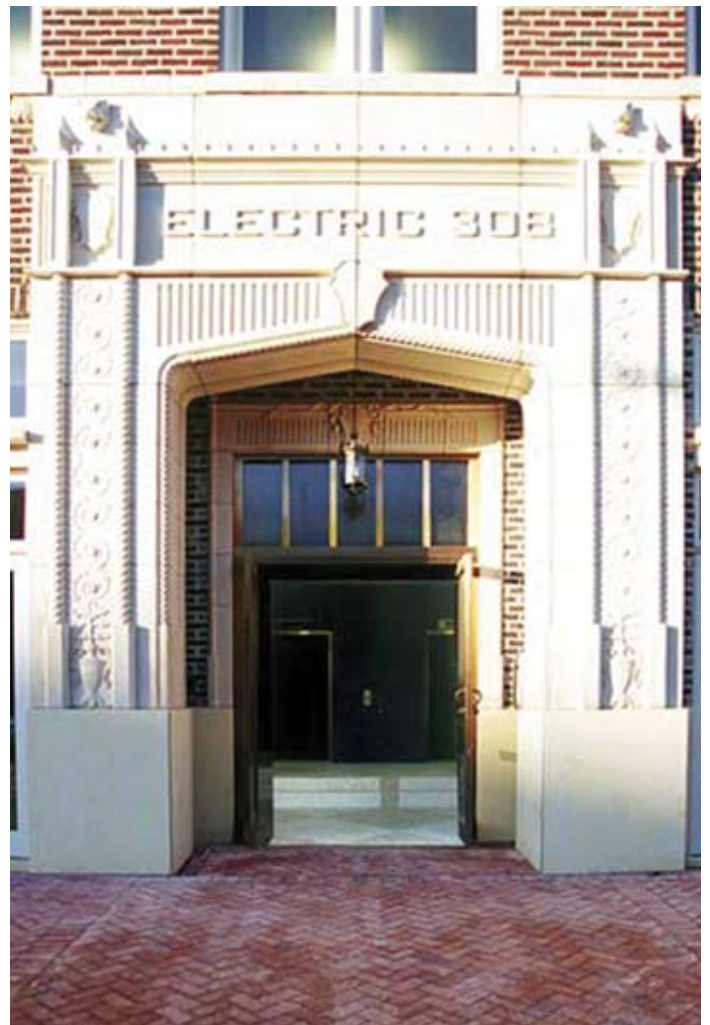

▲ Exterior Entry Facade Restoration

▼ Exterior Square Stacking Columns



▼ Exterior Cornice Restoration



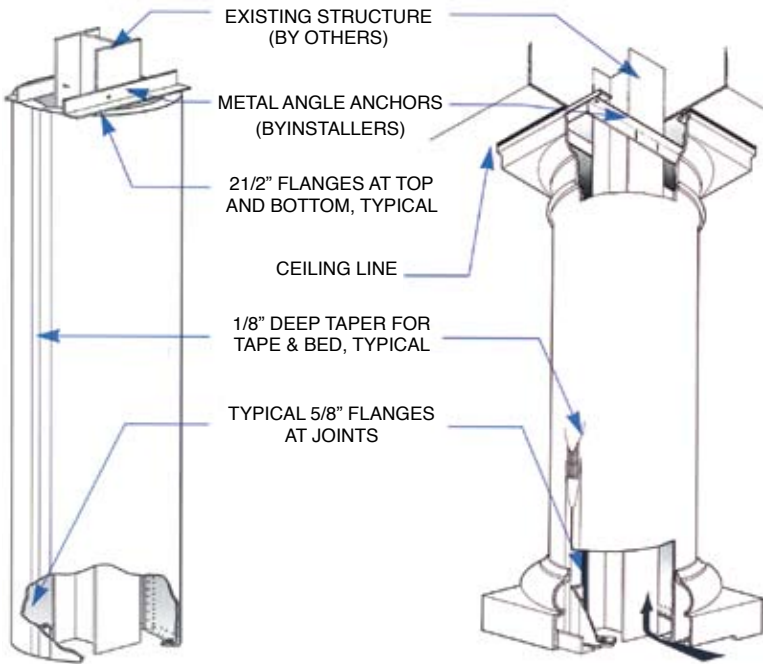

STANDARD COLUMN

Standard columns are available in diameters from 6", 8", 10", etc. to 48". Heights range from a standard 10'-0" to 15'-0". All columns are stepped off at the exact height needed.

COLUMN WITH ADJUSTABLE CAPITAL & BASE

Capitals and bases can be added to either straight shafts or tapered shafts. The design shown above allows the height to be adjustable. This way, one column design can be used in many different ceiling heights keeping cost to a minimum.

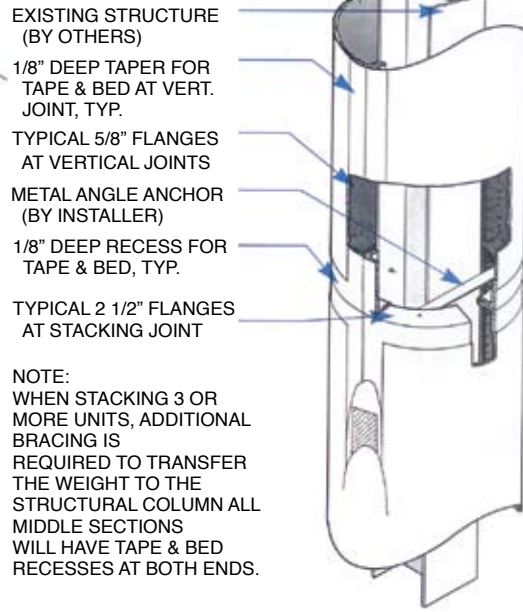

STACKING COLUMN DETAIL

Columns can be stacked to any height needed. Very tall columns are broken into smaller easy to handle sections that are quickly assembled in the field.

NOTE:
WHEN STACKING 3 OR MORE UNITS, ADDITIONAL BRACING IS REQUIRED TO TRANSFER THE WEIGHT TO THE STRUCTURAL COLUMN ALL MIDDLE SECTIONS WILL HAVE TAPE & BED RECESSES AT BOTH ENDS.

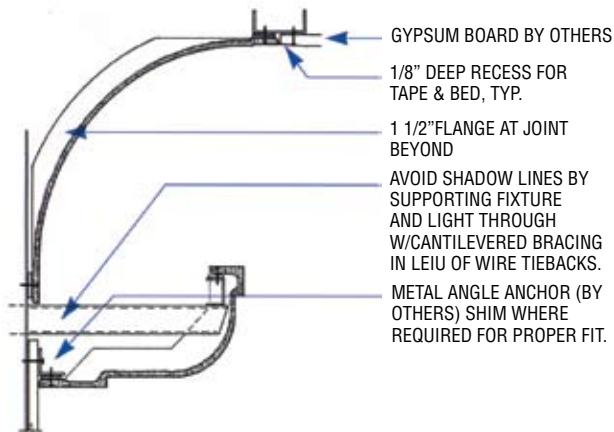

LIGHT COVE

Light cove and reflector cove designs are endless. Options for factory made corners, radiused or mitered, are available. Sections are generally made in 8'-0" lengths with a tape and bed recess at each end. Casting Designs' specialty is creating curved light covers, i.e. around perimeters of domes, rotundas, etc. This type of application cannot be done more cost effectively than by Casting Designs, Inc.

Shown are but a few of the endless number of design possibilities Casting Designs, Inc. has to offer. Choose from a large inventory of stock molds, or use your own imagination to create the perfect design.

With customer service and technical support teams that are second to none. Casting Designs, Inc. can assist you through any stage of design or construction. Contact CDI today and find out what our team can do for you.

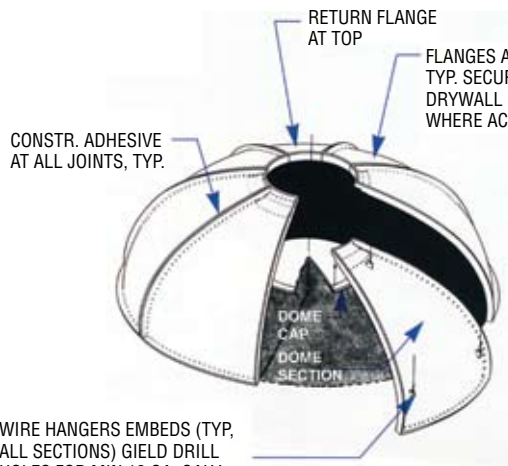

DOMES

Domes, barrel vaults, groin vaults, and cross vaults all are fabricated in lightweight easy to install sections. Most sections are suspended by wire hangers, minimizing the need for framing. Once installed, sections are floated together to form smooth seamless shapes ready to finish.

MATERIAL SPECIFICATIONS

Glass Fiber Reinforced Gypsum (GRG)

Materials

A. GRG members to consist of glass-fiber reinforcing and high strength alpha hemi-hydrate gypsum cement. Members to be of shape, size and thickness as indicated on drawings. Required embeds to be of size and frequency as determined by the manufacturer, and as shown on the shop drawings. All metal embeds to be zinc coated, cadmium plated, galvanized or stainless steel and shall be of perforated metal to facilitate matrix locking.

B. Miscellaneous Materials

1. Fasteners to be standard self tapping drywall screws or self drilling as required by thicker ga. framing. Fastener spacing as specified on shop drawings.
2. Hanger wire to be minimum 12 ga. with corrosion resistant coating or stainless steel.
3. Joint treatment materials to be according to ASTM C-475 guidelines using high quality commercial grade products. Fiberglass tape is recommended for long joints and long runs of GRG.
4. Adhesive to be used at all joints. Adhesive to be structural drywall type such as Miracle DSA-20 or equal.



Fabrication

- A. Molds are to be constructed for GRG units to form shapes and sizes indicated that shall be free of warp and distortion. Members are to be cured under controlled conditions for a sufficient period of time to insure product stability.
- B. Identification/erection marks to be placed in a conspicuous area of unexposed side on all members.
- C. All product to be crated in a substantial manner to insure shipments will arrive damage and distortion free.

Polymer Modified Glass Fiber Reinforced Concrete (GFRC)

Materials

A. GFRC to consist of Type 1 gray portland cement plus washed/dried fine silica sand suitable for masonry mortar (no larger than U.S. No. 20 sieve) with glass fiber reinforcing. The polymer compound add mixture will be specifically designed for use in the manufacture of GFRC. Polymer content will be minimum 5% by volume. Water reducers and plasticizers may be used as required to control water content. Accelerators other than calcium chloride based chemicals may be used.

B. Embeds and inserts to be of size and frequency as determined by the manufacturer and as shown on the shop drawings. All metal embeds to be zinc coated, cadmium plated or stainless steel. Embeds susceptible to deterioration shall not be used.

C. Miscellaneous Materials

1. Fasteners to be cadmium plated or stainless steel.
2. Joint treatment materials to be as recommended by the manufacturer. Fiberglass tape shall be used at the joints.
3. Adhesive to be used at all mating joints which are to be monolithic. Joint adhesive to be exterior grade such as Dow Corning 795 or equal.
4. Sealant used at "stone" joints to be as recommended by the architect or the manufacturer.

Fabrication

- A. Molds are to be constructed for units to form shapes and sizes indicated that shall be free of warp and distortion. Members are to be cured under controlled conditions for a sufficient period of time to insure product stability.
- B. Identification/erection marks to be placed in a conspicuous area of unexposed side of all members.
- C. All products to be crated in a substantial manner to insure shipments will arrive damage and distortion free.

Storage and Installation

All members to be stored under controlled jobsite conditions in a manner which will protect them from damage as well as warp-age and distortion. Consult manufacturers recommendations posted on crates.

All materials shall be installed in strict compliance with all local codes, ordinances and manufacturers recommendations including specific additional requirements as may be called for in the specifications or shown on the drawings.



FIRST PENTECOSTAL CHURCH



Casting Designs Inc.

Glass Fiber Reinforced Gypsum & Concrete

9320 Crowley Rd.
Ft. Worth, TX 76134
800-329-7373
Fax 817-293-8644
www.castingdesingsinc.com